



15370 Barranca Parkway
Irvine, CA 92618-2215



Multi-ISO (OK 5553) RFID Reader

USER MANUAL

© 2009 HID Global Corporation. All rights reserved.

1508-USM-00-0-02

Firmware Version 1.2

August 13, 2009

Doc Number: 1508-USM-00, Rev C.1



Warning - Read before start-up!

- The product may only be used for the intended purpose designed by the manufacturer. The operation manual should be conveniently kept available at all times for each user.
- Unauthorized changes that have not been sold or recommended by the manufacturer may have a negative influence on the system the program has been installed or copied on. Such unauthorized measures shall exclude any liability by the manufacturer.
- The liability-prescriptions of the manufacturer in the issue valid at the time of purchase are valid for the device. The manufacturer shall not be held legally responsible for inaccuracies, errors, or omissions in the manual or automatically set parameters for a device or for an incorrect application of a device.
- Only qualified personnel should carry out installation, operation, and maintenance procedures.
- Use of the program and its installation must be in accordance with national legal requirements.
- When working on devices the valid safety regulations must be observed.

Read Me First

About this Guide

This manual describes the HF Multi ISO Reader. Its goal is to describe the reader, how it works, how to integrate it and how to use it.

Contacts

Europe, Middle East and Africa	
HID Global Corporation, Ltd. (Haverhill, UK)	
email:	eusupport@hidglobal.com
main:	+44 (0) 1440 714 850
support:	+44 (0) 1440 711 822
fax:	+44 (0) 1440 714 840



Contents

- Scope 7**
- Overview 8**
 - Definitions 8
 - Abbreviations 8
 - Supported Tags..... 10
- 1 5553 Reader Core – Multi ISO 12**
 - 1.1 Dimensions 12
 - 1.2 Jumper 1 Details..... 13
 - 1.3 Jumper 2 Details..... 14
 - 1.4 External Connections 15
 - 1.4.1 Power Supply 15
 - 1.4.2 Antenna..... 16
 - 1.4.3 Serial Interface 17
 - 1.4.4 Function Control LEDs 17
 - 1.4.5 SAM Connector/Socket 18
- 2 Software 19**
 - 2.1 Transmission Protocol 19
 - 2.1.1 ASCII Protocol..... 19
 - 2.1.2 Binary Protocol 20
 - 2.2 Register Set 22
 - 2.2.1 EEPROM Memory Organization..... 23
 - 2.2.2 Unique Device ID (00h – 04h) 23
 - 2.2.3 Station ID (0Ah)..... 24
 - 2.2.4 Protocol Configuration 1 (0Bh) 24
 - 2.2.5 BAUD, Baud Rate Control Register (0Ch)..... 25
 - 2.2.6 Command Guard Time (0Dh) 27
 - 2.2.7 OPMODE - Operating Mode Register (0Eh)..... 27
 - 2.2.8 Single Shot Time-Out (0Fh)..... 27
 - 2.2.9 TMR, RF Time-Out Control Register (10h, 11h)..... 27
 - 2.2.10 Type B framing Register (12h) 28
 - 2.2.11 Protocol Configuration 2 (13h)..... 28
 - 2.2.12 Reset Off Time (14h) 29
 - 2.2.13 Reset Recovery Time (15h)..... 29
 - 2.2.14 Application Family Identifier (16h) 29
 - 2.2.15 Selection Time-Out ISO 14443A (17h)..... 30
 - 2.2.16 Selection Time-Out ISO 14443B (18h)..... 30
 - 2.2.17 Selection Time-Out SR176 (19h) 30
 - 2.2.18 Selection Time-Out ISO 15693 (1Ah)..... 30
 - 2.2.19 Protocol Configuration 3 (1Bh) 30
 - 2.2.20 Modulation Conductance 0 (1Dh)..... 31
 - 2.2.21 Threshold (1Eh)..... 31
 - 2.2.22 Protocol Configuration 4 (20h)..... 31



- 2.2.23 CID (21h)..... 32
- 2.2.24 RxWait (22h) 32
- 2.2.25 Modulation conductance 1 (23h) 32
- 2.2.26 Modulation conductance 2 (24h) 32
- 2.2.27 Modulation conductance 3 (25h) 33
- 2.2.28 User data (80h - EFh)..... 33
- 2.3 Command Set..... 34
 - 2.3.1 Common Commands 36
 - 2.3.2 ISO 14443 Type A (MIFARE[®]) only commands 61
 - 2.3.3 Key Management 66
 - 2.3.4 my-d™ secure 73
 - 2.3.5 't' Command – Data Frame Transfer 79
 - 2.3.6 't' command block format & examples 83
 - 2.3.7 'e' command – SAM data frame transfer 86
 - 2.3.8 'e' command block..... 92
- 3 Paypass..... 93**
 - 3.1 Commands 94
 - 3.1.1 Overview 94
 - 3.1.2 Return values 94
 - 3.1.3 Polling..... 94
 - 3.1.4 Activation..... 94
 - 3.1.5 Transaction..... 95
- 4 Frequently Asked Questions 97**
 - 4.1 Getting Started 97
 - 4.2 Personalizing Multi ISO Reader 97
 - 4.3 MIFARE Card Type 98
 - 4.4 MIFARE 98
 - 4.5 Using NFC 99
- 5 Supported Tags..... 100**
 - 5.1 MIFARE Transponder Family 100
 - 5.1.1 MIFARE Standard 100
 - 5.1.2 MIFARE Ultra-light 102
 - 5.1.3 MIFARE 4k 102
 - 5.1.4 MIFARE Prox 102
 - 5.1.5 MIFARE DESFire 103
 - 5.1.6 my-d™ IC (SLE 55Rxx)..... 106
 - 5.2 ISO 14443 Type B 107
 - 5.2.1 SR176 107
 - 5.2.2 SRIX4K..... 108
 - 5.3 ISO 15693..... 109
 - 5.3.1 Coding of UID..... 109
 - 5.3.2 Memory organization 109
 - 5.3.3 my-d™ IC (SRF55VxxP) 109
 - 5.3.4 EM 4135 110
 - 5.4 ICODE 111
 - 5.4.1 Memory organization 111



- 5.4.2 Serial number 111
- 5.4.3 Write access condition..... 111
- 5.4.4 Special function (EAS,) AFI 111
- 5.4.5 User data..... 111
- 5.5 ICODE EPC 112
 - 5.5.1 Memory organization..... 112
 - 5.5.2 Serial number 112
 - 5.5.3 Read Block..... 112
 - 5.5.4 Write Block 112
- 5.6 ICODE UID 112
 - 5.6.1 Memory organization..... 112
 - 5.6.2 Read Block..... 112
 - 5.6.3 Write Block 112
- Appendix A - References..... 113**
- Appendix B - SAM Socket Details 114**
- Appendix C - Timings 115**
- Appendix D 117**
 - 5553 Reader Board RS232 Compact MultiISO (RDHC-020xN0-02) 117
 - 5553 Reader Board USB Comfort Multi ISO (RDHS-0204N0-02)..... 124
 - 5553 Desktop Multi ISO (RDHS-0204D0-02) 129
 - 4553 Mobile Multi ISO (RDHP-0206P0-02) 130
- Appendix E - Version History 131**
- Appendix F - Approvals / Certificates 132**
 - CE Declaration 132
 - FCC Declaration..... 133
 - RoHS Compliance..... 134

List of Figures

- Figure 1 - Reader Core - Top View..... 12
- Figure 2 - Power Supply Option 1 15
- Figure 3 - Power Supply Option 2 16
- Figure 4 - Typical Antenna Tuning..... 16
- Figure 5 - OEM Board Serial Interface..... 17
- Figure 6- Connecting External LEDs - Option 1..... 17
- Figure 7 - Connecting External LEDs - Option 2..... 17
- Figure 8 - SAM Connector 18
- Figure 9 – KTT State Diagram 77
- Figure 10 – Mifare State Diagram 101
- Figure 11 - DESFire Memory 103
- Figure 12 - DESFire State Diagram 104
- Figure 13 - 5553 Reader RS232 Compact Multi ISO - Top View 118



Figure 14 - 5553 Reader RS232 Compact Multi ISO - Side View 119
Figure 15 - 5553 Reader RS232 Compact Multi ISO - Front View 119
Figure 16 - Pin Out – Jumper 3..... 119
Figure 17 - RS232 Configuration - Jumper 3 Pin Out..... 120
Figure 18 - RS422 Configuration - Jumper 3 Pin Out..... 121
Figure 19 – RS485 Configuration - Jumper 3 Pin Out..... 122
Figure 20 - Jumper 4 Pin Out - Top View 123
Figure 21 - Jumper 4 Pin Out..... 123
Figure 22 - 5553 Reader USB Comfort Multi ISO - Top View 125
Figure 23 - 5553 Reader USB Comfort Multi ISO - Front View 126
Figure 24 - 5553 Reader USB Comfort Multi ISO - Bottom View 127
Figure 25 - 5553 Reader USB Comfort Multi ISO - Jumper 5 Pin Out - Top View 128

List of Tables

Table 1 - Pin out – Jumper 1..... 13
Table 2 - Electrical characteristics of J1 PINs..... 13
Table 3 - Pin out – Jumper 2..... 14
Table 4 - Electrical characteristics of J2 PINs..... 14
Table 5 - Common Command Overview..... 34
Table 6 - Card Specific Commands 35
Table 7 - Error Codes..... 35
Table 8 - Register Type with Corresponding Register 50
Table 9 - Sending Serial Data Frame 53
Table 10 - Receiving Serial Data Frame 54
Table 11 - Version 1 (Option Byte) 87
Table 12 - Version 2 (Option Byte) 88
Table 13 - Timings 115
Table 14 - Pin out – Jumper 3 Detail 120
Table 15 - J3 pins in RS232 Configuration - Electrical Characteristics 120
Table 16 - J3 pins in RS422 Configuration - Electrical Characteristics 121
Table 17 - J3 pins in RS485 Configuration - Electrical Characteristics 122
Table 18 - J4 pins - Electrical Characteristics..... 123
Table 19 - Pin Out of Jumper 5..... 128
Table 20 – J5 Pin - Electrical Characteristics 128



Scope

The HID HF Multi ISO Reader Module supports a broad range of tags compliant with ISO 14443 type A and B standards, including SR176 tags, tags which belong to the NXP MIFARE family, ISO 15693 tags, ISO 18000-3, EPC and UID tags. An open command structure allows the device to communicate with tags that use an operating system. The read/write unit supports ISO 14443-4 layer with automatic chaining, 256 byte buffer and frame length, extended time framing and up to 848kBaud transmission rates over the air interface.

Several protocols are available to enable the reader module to be connected to a variety of equipment. The ASCII protocol facilitates the use of a simple terminal; the Binary protocol provides robust communication more suitable for a dedicated host system. If a host computer is used, then a function library is available, providing function calls rather than low-level 'byte-bashing'.

For the SAM interface security features and DESFire credential DES encryption, the function library provides access to these features in the Reader Module. The function library is available for Windows CE and XP host applications.

Major applications are:

- Access control, identification using security credentials
- Ticketing using standard MIFARE and DESFire credentials

Overview

Definitions

Anti-collision loop

An algorithm used to identify and handle a dialogue between a reader and one or more tags in its antenna field.

ASCII notation

ASCII characters are listed within apostrophes, i.e. 'x' means a single x.

Command	Parameter	Description
Read register		

Hex notation

A hexadecimal value is marked with the suffix 'h', i.e. A1h has the value A1 hexadecimal.

Command	Parameter	Description
Read register	0Ah	Read register 0Ah Data has 1 character / byte

Abbreviations

Abbreviation	Description
AID	Application ID
ASCII	American Standard Code for Information Interchange
ATR	Answer to Reset
ATS	Answer to Select
AFI	Application Family Identifier
Block	For the MIFARE Standard one block contains 16 bytes
CBC	Cipher Block Chaining
CID	Card Identifier (logical card address, ISO 14443-4)
CRC	Cyclic Redundancy Check
DES	Data Encryption Standard, for more details about DES refer to [3].
DSFID	Data storage format identifier
EDC	Error Detection Code
EGT	Extra Guard Time
EOF	End of Frame
ETU	Elementary time unit
Hex / xxh	Value in Hexadecimal notation
I-block	Information block
KTT	Key Transfer Transponder
LSB	Least Significant Bit or Byte
MSB	Most Significant Bit or Byte
NAD	Node Address (ISO 14443-4)



Abbreviation	Description
OSI	Open System Interconnection
OTP	One time programmable
PCB	Protocol Control Byte (ISO 14443-4)
PCON	Protocol Configuration byte of the reader
PPS	Protocol and Parameter Selection
RATS	Request for Answer to Select
R-block	Receive ready block
REQA	Request ISO Type A
REQB	Request ISO Type B
RFU	Reserved for Future Use
S-block	Supervisory block
SAM	Secure Application Module
Sector	For the MIFARE Standard one sector contains 4 blocks
SID	Station ID
SFGT	Guard time after RATS
SN	Serial Number of a tag (a 32 bit number)
SOF	Start of frame
TDES	Triple DES
Value block	32 bit data block format. Used in ticketing application
<CR>	Carriage return (0Dh)
<LF>	Line feed (0Ah)



Supported Tags

For tag details see Supported Tags, page 100.

Tag	Manufacturer	Serial number	Read/Write operation	Transfer command	Comments
ISO 14443 A					
MIFARE Standard	NXP	√	√	√	
MIFARE 4k	NXP	√	√	√	
MIFARE Ultra-light	NXP	√	√	√	
MIFARE ProX	NXP	√	√	√	
MIFARE DESFire	NXP	√	-	√	
MIFARE Mini	NXP	√	√	√	
SLE66CLX320P	Infineon	√	-	√	encryption not included
SLE 55R04 / 08	Infineon	√	-	√	encryption included
Smart MX	NXP	√	-	√	
Jewel	Innovision	√	√	√	
Topaz	Innovision	√	√	√	
ISO 14443 B					
SLE6666CL160S	Infineon	√	-	√	
SR176	STM	√	√	√	
SLIX 4K	STM	√	√	√	
ASK GTML2 ISO	ASK	√	-	√	
ASK GTML	ASK	√	-	√	extended setup needed
Sharp B	Sharp	√	-	√	
TOSMART P0032/64	Toshiba	√	-	√	
Dual Interface					
ISO 14443 A compliant ¹	various	√	-	√	
ISO 14443 B compliant ²	various	√	-	√	
ISO 15693					

¹ Performance varies

² Performance varies



Tag	Manufacturer	Serial number	Read/Write operation	Transfer command	Comments
EM 4135	EM	√	√	√	
ICode® SLI	NXP	√	√	√	
LRI12	STM	√	√	√	
LRI64	STM	√	√	√	with 10% modulation index
LRI128	STM	√	√	√	
LRI2k	STM	√	√	√	better performance with 10% modulation index
SRF55VxxP	Infineon	√	√	√	
SRF55VxxS	Infineon	√	√	√	encryption included
Tag-it™ HF-I Std	TI	√	√	√	
Tag-it™ HF-I Pro	TI	-	-	√	only in addressed mode
TempSense	KSW	√	-	√	Temperature logging
ICode					
ICode®	NXP	√	√	√	
ICode® EPC	NXP	√	√	√	
ICode® UID	NXP	√	√	√	

1 5553 Reader Core – Multi ISO

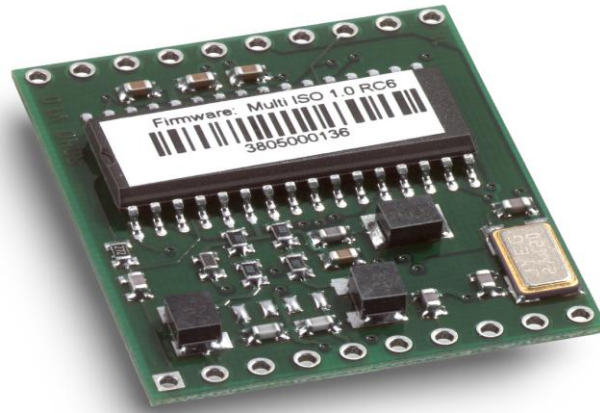

1.1 Dimensions

All dimensions listed in millimeters.

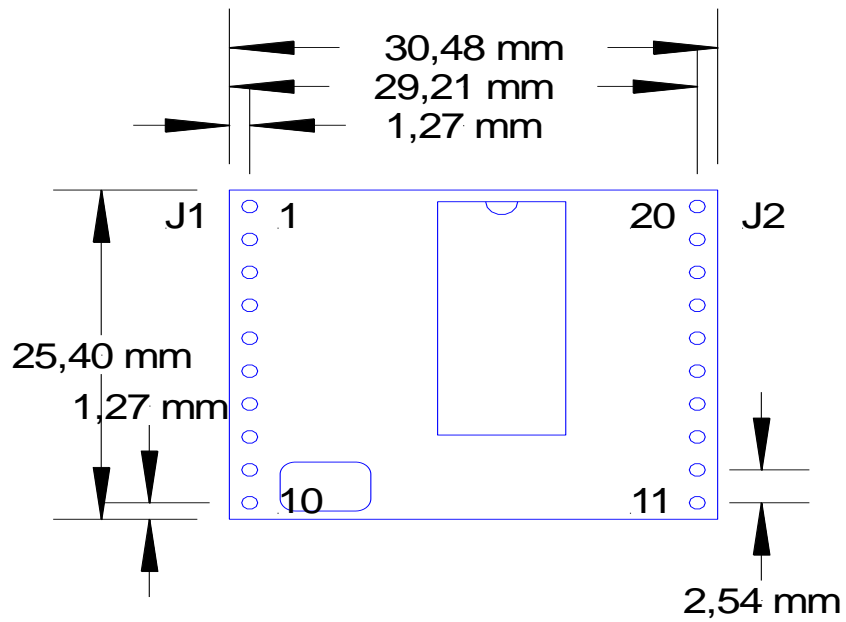

Figure 1 - Reader Core - Top View



1.2 Jumper 1 Details

Table 1 - Pin out – Jumper 1

PIN	PIN No.	Description
ARX	1	Antenna RX
ATX1	2	Antenna TX1
VDD	3	Supply Voltage
GND	4	Ground
ATX2	5	Antenna TX2
TGND	6	Antenna Ground
SAM CLK	7	SAM clock
SAM IO	8	SAM IO
SAM RESET	9	SAM Reset
RTS	10	Request to Send

Table 2 - Electrical characteristics of J1 PINS

PIN	PIN No.	Min	Typ.	Max.	Description
ARX	1	1.1V		4.4V pk-pk	Antenna RX
ATX1	2		13,56 MHz 34 V _{PP}	13.56MHz 100 mA _{PP} 50V _{PP}	Antenna TX1
VDD	3	+4.5V	+5.0V	+5.5V	Supply Voltage
		32mA	150mA	250mA	Supply Current (without SAM)
GND	4		GND		Ground
ATX2	5		13,56 MHz 34 V _{PP}	13.56MHz 100 mA _{PP} 50V _{PP}	Antenna TX2
TGND	6		GND		Antenna Ground
SAM CLK	7		TTL		SAM clock
				25mA	
			3,39MHz		
SAM IO	8		TTL	25 mA	IO for SAM Input and SAM Output
SAM RESET	9		TTL	25 mA	SAM Reset
RTS	10		TTL	25 mA	Request to Send

1.3 Jumper 2 Details

Table 3 - Pin out – Jumper 2

PIN	PIN No.	Description
VDD	20	Supply Voltage
GND	19	Ground
LEDg	18	LED green (reading LED)
LEDr	17	LED red
EN	16	Enable reader, open or logic high
MCLR	15	Master clear
USER	14	User Port
DIR	13	Direction of RS 485
TX	12	TX to PC
RX	11	RX from PC

Table 4 - Electrical characteristics of J2 PINs

PIN	PIN No.	Min	Typ.	Max.	Description
RX	11		USART-TTL ¹	25 mA	Rx to PC To RS232, RS485 or RS422 device driver
TX	12		USART-TTL ¹	25 mA	Tx to PC To RS232, RS485 or RS422 device driver
DIR	13		TTL	25 mA	Direction of RS 485 Logic High = Reader to Host Logic Low = Host to Reader
USER	14		TTL ³	25 mA	User Port
MCLR	15		TTL ⁴		Master clear Leave unconnected. Low will reset the register and the key management to default values.
EN	16		ST ⁵	25 mA	Enable reader logic low will disable the reader Open or logic high
LEDr	17	VDD _{min} @ 25mA	VDD _{typ} @ 11mA	VDD _{max} @ 0 mA	LED red Output Voltage

¹ Universal Synchronous Asynchronous Receiver Transmitter

³ TTL buffer output / input. If user port is used as an output, a 1kΩ (current limiting) series resistor has to be integrated into the connecting wire, otherwise the reader device can be damaged.

⁴ Voltage spikes below GND at the MCLR/VDD pin, including currents greater than 80mA, may cause latch-up. Thus, a series resistor of 50-100Ω should be used when applying a "low" level to the MCLR/VDD, rather than pulling this pin directly to GND.

⁵ Schmitt trigger buffer input

PIN	PIN No.	Min	Typ.	Max.	Description
			11mA	25mA	External Resistor min. 200 Ω
LEDg	18		1.4V @ 11mA	VDD @ 0mA	LED green (reading LED) with 330 Ω (internal serial) resistor
			11mA	15mA	
GND	19		GND		Ground
VDD	20	+4.5V	+5.0V	+5.5V	Supply Voltage
IDD		32 mA	150 mA	250 mA	Supply Current (Without SAM)

1.4 External Connections

1.4.1 Power Supply

If the supply voltage and any noise modulated on the supply voltage remains within the specified limits, no further filtering is required. In some cases it is recommended to use additional filtering for the power supply line. Insufficient power line filtering could cause unexpected or irregular performance drops.

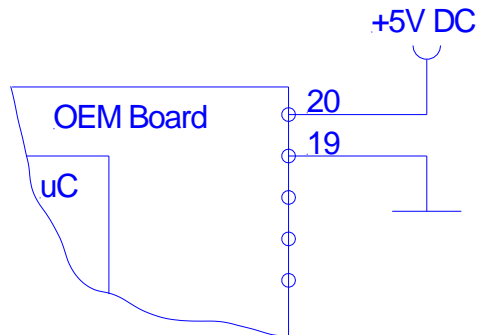

Figure 2 - Power Supply Option 1

The board can be connected as shown in Figure 3 - Power Supply Option 2. Both alternatives are possible and can be used as they fit best into the layout of the carrier board. The two VCC PINs and the two GND PINs are connected internally.

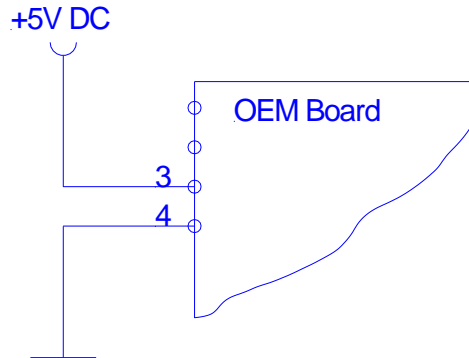

Figure 3 - Power Supply Option 2

1.4.2 Antenna

The typical antenna tuning and matching network is shown in Figure 4 - Typical Antenna Tuning. The external antenna has to have the right inductance and a certain resistor and capacitor combination for an optimized frequency tuning and antenna matching.

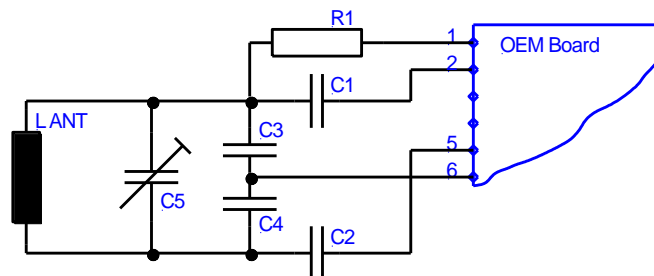

Figure 4 - Typical Antenna Tuning

More details about the antenna design are available in the HID Antenna Design guide. Download this document from <http://www.hidglobal.com/Omnikey>.

Reference the specific application notes for the NXP reader IC (MIFARE & I-Code, Micore Reader IC family Directly Matched Antenna Design).

1.4.3 Serial Interface

The OEM Board can be connected directly with a micro controller. Alternatively the OEM Board also can be connected to most serial interface types by using the right interface converter circuit. In order to optimize the communication quality the specific application note of the interface converter circuit needs to be taken into consideration.

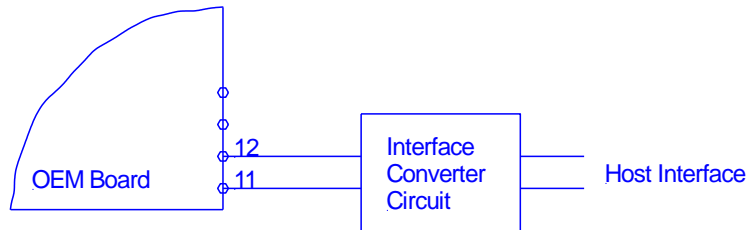

Figure 5 - OEM Board Serial Interface

1.4.4 Function Control LEDs

Two external LEDs can be connected to the OEM Board. There are two alternatives possible.

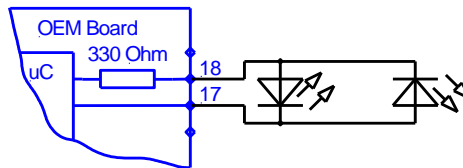

Figure 6- Connecting External LEDs - Option 1

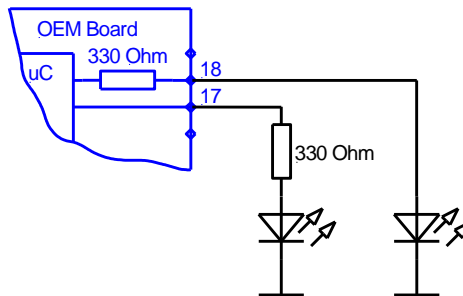

Figure 7 - Connecting External LEDs - Option 2

In both cases the LED supply voltage levels are TTL levels.

1.4.5 SAM Connector/Socket

Note: The power supply to the SAM must be turned off during the entire SAM insertion/withdrawal period; otherwise damage to the SAM may occur.

When using a SAM with the OEM board, it is recommended that a 100nF decoupling capacitor be fitted between Vcc and GND close to the SAM socket to ensure proper operation. The complete circuit diagram is shown in Figure 8 - SAM Connector.

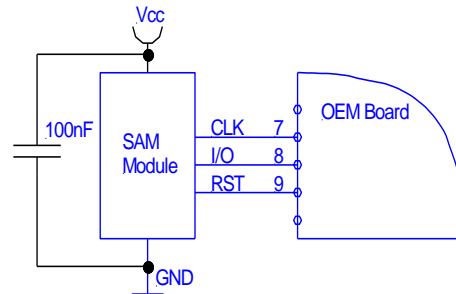

Figure 8 - SAM Connector

PIN-outs for 8 Pin SAM Socket and 6 Pin SAM Socket is shown in [Appendix B](#).

Note: The SAM interface hardware does not support error repetition and does not check the parity bit.



2 Software

In order to offer the widest possible choice of interface, the MultiISO reader offers both ASCII and Binary serial protocols – see Transmission Protocol, page 19.

EEPROM registers in the reader hold default settings for Station ID, protocol, serial and air-speed settings, timing parameters and modulation index – listed in Register Set, page 22. These registers are alterable using the Read/Write EEPROM commands detailed in

Command Set page 34. The register settings are applied to the reader through the configuration registers.

These configuration registers may be altered ‘on-the-fly’ to immediately affect performance by the ‘set configuration flag/register’ commands, but the changes are lost once the reader is powered down, unless also written into the EEPROM registers. These and all other configurable settings are detailed in the Register Set – Register Set, page 22.

General reader commands are listed in

Command Set, page 34 and detailed in

Common Commands, page 36, dealing with the physical attributes of the reader – reset, LED control, User port control, Antenna power – and the basic tag commands – include/exclude tag types, continuous read, tag select and air speed select, and simple block read/write commands.

Tag-specific commands for MIFARE and My-D tags are listed in Sections ISO 14443 Type A (MIFARE®) only commands, page 61 and my-d™ secure, page 73, and commands to manipulate keys are listed in Key Management, page 66.

For more complex commands, the ‘t’ command is used. This uses a data frame or packet to exchange information – see ‘t’ Command – Data Frame Transfer, page 79 and ‘t’ command block format & examples, page 83 for examples of use

To communicate with the optional SAM, the ‘e’ command is used. This also encapsulates a data frame/packet to exchange information, based on the ISO7816 APDU – see ‘e’ command – SAM data frame transfer, page 86 and ‘e’ command block, page 92 for examples of use.

2.1 Transmission Protocol

Two protocol modes are supported, with the default held in the reader EEPROM. As factory default, the ASCII protocol is used, and the default serial configuration is 9600baud, n, 8, 1, with no handshaking.

2.1.1 ASCII Protocol

This protocol is designed for easy handling. The commands may be issued using a terminal program, such as HyperTerminal, and the data is transmitted as ASCII hexadecimal that can be easily displayed on the terminal program.

Command	Data
Variable length	Variable length

2.1.2 Binary Protocol

This protocol is designed for industrial applications with synchronization and frame checking. An addressing byte for party line (master/slave, multi-drop) is also included.

The protocol usually requires a device driver. Data is transmitted in binary mode. The reader uses an internal binary watchdog timer to ensure correct framing.

STX	Station ID	Length	Data	BCC	ETX
1 byte	1 byte	1 byte	Variable length	1 byte	1 byte

The binary frame version 2 is only sent to the host. It is implemented to give extended information to the host.

Version 2 must be enabled in the Protocol configuration 2 register.

STX	Station ID	Length	Flags	Data	BCC	ETX
1 byte	1 byte	1 byte	1 byte	Variable length	1 byte	1 byte

2.1.2.1 STX

Start of transmission (02h)

2.1.2.2 Station ID

Unique ID of the station

00h: Reserved for the bus master. Readers send response to this device ID.

FFh: Broadcast message. All devices will execute the command and send their response.

2.1.2.3 Length

Length defines the length of the data block, including the flag byte, if binary protocol version 2 is activated.

If length is set to zero, 256 data bytes are transmitted. The reader module only can send 256 data bytes, but cannot receive commands with 256 bytes.

2.1.2.4 Flags

The flag byte gives additional information to the host.

Bit 3 – Bit 7	Bit 1 – Bit 2	Bit 0
RFU	Leading Character Info	Error State

Error State

If cleared, the command was processed successfully.

If Error State is set, an error occurred.



Leading Character Info

Bit 1 & 2 defines how to interpret the data in the binary frame.

Bit 2	Bit 1	Description
0	0	No leading character available, all values are hexadecimal.
0	1	The data contains one leading character.
1	0	All data bytes are characters.
1	1	RFU

2.1.2.5 Data

This part contains the command and the data. The command values are the same as in ASCII protocol mode ('x', 's', ...) whereas data is transmitted in binary mode.

The length of the command block depends on the instruction.

2.1.2.6 Block Check Character (BCC)

The BCC is used to detect transmission errors. The BCC is calculated XOR-ing each byte of the transmission frame excluding the STX/BCC and ETX characters. The flags are part of the data.

$$BCC = (StatID) XOR(Length) XOR(Command / Data_0) XOR... XOR(Command / Data_N)$$

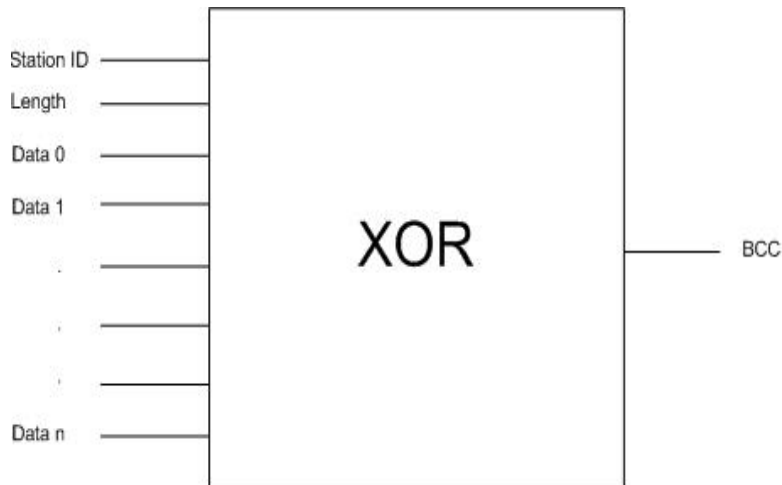

2.1.2.7 ETX

End of transmission. (03h)



2.1.2.8 Remarks

If the reader device receives an invalid instruction frame (i.e. wrong BCC) or the requested station ID does not match the internal ID of the reader, the command is not executed. The reader waits for the next valid frame.

The automatic binary time-out (see Protocol Configuration 1 (0Bh), page 24) is used to detect incomplete binary frames.

2.1.2.9 Examples

02h	64h	01h	78h	1Dh	03h
STX	Station ID	Length	'x'	BCC	ETX

This instruction frame will reset the reader module with the station ID 64h.

2.2 Register Set

The reader has several system registers used for customization purposes. These registers are stored in its non-volatile EEPROM. The reader accepts changes to these settings only during the start-up phase. [See Write EEPROM, page 60]

Some of the system registers are organized such that each of the 8 bits is an on-off selection for a feature. These are referred to as Flags. [See Set Configuration Flags, page 48]

Clearing all RFU bits is recommended in order to guarantee compatibility with future releases.

In addition, direct changes to some of these system registers may be made at any time, with immediate effect, but these changes are NOT stored in EEPROM and thus are lost when the reader powers down. [See Set Configuration Flags, page 48 and Set Configuration Register, page 50]

These 'on-the-fly' changes are mapped onto the EEPROM 'registers' or memory locations and do not necessarily carry the same 'register' values.

The reader can store up to 32 authentication keys internally to login standard MIFARE cards. An additional 32 keys can be stored for DESFire authentication. All keys are read only and cannot be accessed through the interface lines.



2.2.1 EEPROM Memory Organization

Register	Description
00h ... 04h	Unique device ID; read only
05h ... 09h	Administrative data; read only
0Ah	Station ID
0Bh	Protocol configuration 1
0Ch	Baud rate
0Dh	Command Guard Time
0Eh	Operation Mode
0Fh	Single shot time-out value
10h	TMR low *
11h	TMR high *
12h	Type B framing *
13h	Protocol configuration 2
14h	Reset Off Time
15h	Reset Recovery Time
16h	Application Family Identifier
17h	ISO 14443A Selection Time-out
18h	ISO 14443B Selection Time-out
19h	SR176 Selection Time-out
1Ah	ISO 15693 Selection Time-out
1Bh	Protocol configuration 3
1Ch	Page Start
1Dh	Modulation conductance 0 (Type B and SR176. Also ISO15693 if set to 10% modulation)
1Eh	Threshold
1Fh	Page number
20h	Protocol configuration 4
21h	CID
22h	RxWait
23h	Modulation conductance 1 (Type B and SR176)
24h	Modulation conductance 2 (Type B and SR176)
25h	Modulation conductance 3 (Type B and SR176)
26h - 7Fh	RFU
80h ... EFh	User data

2.2.2 Unique Device ID (00h – 04h)

The unique device ID identifies a reader module. It is factory programmed and cannot be changed.

2.2.3 Station ID (0Ah)

Default = 01h

The station ID is used in binary mode to address a device in party line set up. The station ID can range from 01h to FEh and can be set freely. The value 00h is reserved for the bus master. All readers send their response to this device.

The broadcast message (FFh) forces all readers to response to the command.

2.2.4 Protocol Configuration 1 (0Bh)

Default = 41h

The protocol configuration register (PCON) specifies general behavior of the reader device, using bit flags.

Protocol configuration register							
Bit 7	Bit 6	Bit 5	Bit 4	Bit 3	Bit 2	Bit 1	Bit 0
Extended ID	Extended Protocol	Single-shot	LED	New serial mode	Multitag	Protocol	Auto- start

2.2.4.1 Auto start (default 1)

If set, the reader device will start up in continuous read mode automatically.

This is only valid in ASCII mode.

2.2.4.2 Protocol (default 0)

If Protocol is set to '1', then the reader uses binary protocol mode. See Binary Protocol, page 20 for further information on the binary protocol format. **Default setting** = ASCII protocol (0).

2.2.4.3 Multitag (default 0)

The Multitag flag will enable multi-tag recognition in continuous read mode. All tags are detected and displayed. Due to the more complex search algorithm, the continuous read command decreases its detection speed.

2.2.4.4 New Serial Mode (default 0)

If New Serial Mode is set to '1', new serial mode is enabled. A leading character is added to the serial number.

Leading Character	Description
D	ICode UID
E	ICode EPC
I	ICode
J	ISO 14443 A Jewel tag
M	ISO 14443 A
S	SR 176
V	ISO 15693
Z	ISO 14443 B



2.2.4.5 LED (default 0)

If set the reader suppresses any LED activity. The user manages the state of the LEDs.

2.2.4.6 Single Shot (default 0)

If Single Shot is set, the reader displays the serial number of a tag in continuous read mode once within a specified time-out. The time-out is defined at EEPROM register 0Fh.

The delay time can be adjusted stepwise in 100ms steps. 00h indicates no delay and FFh indicates infinite delay.

Note: The delay precision depends on reset off and reset recovery time.

2.2.4.7 Extended Protocol (default 1)

If Extended Protocol is set, the transfer data telegram command supports ISO14443-4 and automatically process the WTX and chaining for smaller frames. This flag has to be set to enable 14443-4 error handling – see Extended Protocol (default 1), page 25.

If sending ISO 14443-3 commands this flag has to be switched off.

The transfer data telegram command is only supported in normal mode, not in transmit / receive mode.

2.2.4.8 Extend ID (default 0)

If the Extend ID is set, the reader extends the serial number with additional information.

ISO 14443 A tags

Tag type / ReqA	Serial number	[SAK]
1 byte / 2 bytes	4 / 7 / 10 bytes	1 byte

Tag type / ReqA	Serial number	[SAK]	ATS	Used Speed	[CID]
1 byte / 2 bytes	4 / 7 / 10 bytes	1 byte	n bytes	1 byte	1 byte

The tag type byte indicates the type of cascade level.

Tag type	Description
00h	Cascade level 1 transponder
01h	Cascade level 2 transponder
02h	Cascade level 3 transponder

ISO 14443 B tags

Serial number	Application data	Protocol info	MBLI/CID
4 bytes	4 bytes	3 bytes	1 byte

Serial number	Application data	Protocol info	MBLI / CID	Used Speed	[CID]
4 bytes	4 bytes	3 bytes	1 byte	1 byte	1 byte

For detailed description of Application Data, Protocol Info and MBLI/CID, refer to the ISO 14443 documentation [1].

2.2.5 BAUD, Baud Rate Control Register (0Ch)

Default = 00h

The baud rate register defines the communication speed of the reader device.

Baud rate register							
Bit 7	Bit 6	Bit 5	Bit 4	Bit 3	Bit 2	Bit 1	Bit 0
RFU	RFU	RFU	RFU	RFU	BS2	BS1	BS0

This register defines the baud rate of the device.

BS2	BS1	BS0	Baud rate
0	0	0	9600 baud (default)
0	0	1	19200 baud
0	1	0	38400 baud
0	1	1	57600 baud
1	0	0	115200 baud
1	0	1	230400 baud (depends on the used interface chip)
1	1	0	460800 baud (depends on the used interface chip)

With the high baud rates (230400 and 460800 baud), proper operation depends on the interface chip used. Please note that some of the interface chips available do not support these high baud rates.

The following table describes the exact baud rates used by the reader.

Baud rate	Exact baud rate	Difference
9600 baud	9603 baud	0.03 %
19200 baud	19207 baud	0.04 %
38400 baud	38305 baud	-0.25 %
57600 baud	57458 baud	-0.25 %
115200 baud	114915 baud	-0.25 %
230400 baud	233793 baud	1.47 %
460800 baud	452000 baud	-1.91 %

The following table describes the communication settings.

Description
8 data bits
No parity bit
1 stop bit
No flow control

2.2.5.1 CF Card Version

The Baud rate of the CF Card version is limited to 115200 baud. 230400 and 460800 are not supported.



2.2.6 Command Guard Time (0Dh)

Default = 20h (1,2ms)

The Command Guard Time is used to ensure that commands are not sent too fast consecutively. Following commands are sent after the guard time is elapsed. One time slice is around 37,8us. The longest timeout value is 9,6ms (FFh).

2.2.7 OPMODE - Operating Mode Register (0Eh)

Default = FFh (all)

The operation mode register defines which tag types the reader supports. This register enables fast tag recognition because only defined tag types are requested.

Operation mode register							
Bit 7 (MSB)	Bit 6	Bit 5	Bit 4	Bit 3	Bit 2	Bit 1	Bit 0 (LSB)
RFU	ICODE UID	ICODE EPC	ISO 15693	ICODE	SR176	ISO 14443B	ISO 14443A

Innovision Jewel tag

Innovision Jewel tag is part of ISO 14443 Type A. It can not be separately switched on/off.

2.2.8 Single Shot Time-Out (0Fh)

Default = 0Ah (1 sec)

The time-out value defines the delay time between two responses of the reader. It only has effect in continuous read mode. To enable the time-out, the single shot flag has to be set. See Protocol Configuration 1 (0Bh), page 24. One time-out slice is around 100ms. Exact timing depends on the protocol used.

Value 00h indicates no delay time.

2.2.9 TMR, RF Time-Out Control Register (10h, 11h)

Default = 0300h (~230mS)

The RF time-out is used as reader card communication time-out. One time slice is around 300µs. The longest time-out value is 19.7 seconds (FFFFh).

Value 0000h is not allowed and internally set to 0001h.

2.2.10 Type B framing Register (12h)

Default value is 27h.

This register defines the communication settings of ISO 14443 B cards. The user can adjust this register to set up the framing of type B cards individually. The register is applied when the operating mode is set to type b ('ob') or toggle mode ('ot').

Type B Framing register							
Bit 7	Bit 6	Bit 5	Bit 4	Bit 3	Bit 2	Bit 1	Bit 0
NoTx SOF	NoTx EOF	EOF Width	CharSpacing			SOFWidth	

Bit	Description
NoTx SOF	If set to 1 no SOF is sent
NoTx EOF	If set to 1 no EOF is sent
EOF Width	0 Set the EOF to a length of 10 ETU 1 Set the EOF to a length of 11 ETU
CharSpacing	Set the length of the EGT between 0 and 7 ETU
SOFWidth	00 Set the SOF to a length of 10 ETU low and 2 ETU high 01 Set the SOF to a length of 10 ETU low and 3 ETU high 10 Set the SOF to a length of 11 ETU low and 2 ETU high 11 Set the SOF to a length of 11 ETU low and 3 ETU high

2.2.11 Protocol Configuration 2 (13h)

Default value is 00h.

The protocol configuration register 2 (PCON2) further specifies the general behavior of the reader device.

Protocol configuration 2 register							
Bit 7	Bit 6	Bit 5	Bit 4	Bit 3	Bit 2	Bit 1	Bit 0
Disable ISO 14443 - 4 Error Handling	Enable ISO 14443B Anti-collision	Reset Recovery Time Multiplier		Noisy Environment	Enable binary frame v2	Disable start-up message	Disable multi-tag reset

2.2.11.1 Disable multi-tag reset: bit 0 (default 0)

If set, the reader does not reset before the multi-tag list and multi-select command have been performed.

2.2.11.2 Disable start-up message: bit 1 (default 0)

If Disable start-up message is set, the reader suppresses the start-up message in ASCII mode. This flag is ignored in binary protocol mode.

2.2.11.3 Enable binary frame v2: bit 2 (default 0)

If Enable binary frame v2 is set, the reader sends version 2 binary frames.

The get station ID command always sends version 1 binary frames!



2.2.11.4 Noisy Environment : bit 3 (default 0)

If Noisy Environment is set, the continuous read mode can only be aborted with the '.' character. When working in a noisy environment, the probability for a reception of an arbitrary/stochastic signal is quite high. This implies a high probability of an unintentional command execution. To reduce this probability, only one character (out of 255) is chosen ('.') to be interpreted as the continuous read stop command.

2.2.11.5 Reset Recovery Time Multiplier: bits 4-5 (default 0)

Multiplies the Reset Recovery Time, including the recovery time of the field reset command.

Reset Recovery Time Multiplier	Reset Recovery Time
0	1x
1	2x
2	3x
3	4x

2.2.11.6 Enable ISO14443 B Anti-collision (default 0)

If set, the anti-collision algorithm for ISO 14443 B tags is enabled.

2.2.11.7 Disable ISO 14443-4 Error Handling (default 0)

If set, ISO14443-4 Error Handling is disabled. The error handling always uses the TMR time-out. To enable Error Handling, the Extended Protocol flag in Protocol configuration 1 must be set. See Extended Protocol (default 1), page25.

2.2.12 Reset Off Time (14h)

Default value is 0Ah.

The Reset Off Time register represents the field off time in ms.

This register is used for the select, continuous read and multi-tag commands.

2.2.13 Reset Recovery Time (15h)

Default value is 25h.

The Reset Recovery Time register represents the recovery time in ms after the field is turned on.

This register is used for the select, continuous read and multi-tag commands.

2.2.14 Application Family Identifier (16h)

Default value is 00h.

The AFI (Application Family Identifier) is only supported for ISO14443B and ISO15693 tags. If the set value is different from 00h, the AFI is used. Only transponders with an identical AFI will answer to the reader.

2.2.15 Selection Time-Out ISO 14443A (17h)

The default value is 10h. (~4.8mS)

The Selection Time-out represents the reader card communication time-out for the select, high-speed select, continuous read, multi-list, multi-select and MIFARE login command with ISO 14443A tags. Use low values for a better reaction time between the card and the reader. One time slice is around 300us.

2.2.16 Selection Time-Out ISO 14443B (18h)

The default value is 10h. (~4.8mS)

The Selection Time-out represents the reader card communication time-out for the select, high-speed select, continuous read, multi-list and multi-select commands with ISO 14443B tags. For a better reaction time, use low values. One time slice is around 300µs.

2.2.17 Selection Time-Out SR176 (19h)

The default value is 10h. (~4.8mS)

The Selection Time-out represents the reader card communication time-out for the select, continuous read, multi-list and multi-select command with SR176 tags. For a better reaction time, use low values. One time slice is around 300µs.

2.2.18 Selection Time-Out ISO 15693 (1Ah)

The default value is 10h. (~9.6mS)

The Selection Time-out represents the reader card communication time-out for the select, high-speed select, continuous read, multi-list, multi-select and MIFARE login command with ISO 15693 tags. Use low values for a better reaction time between the card and the reader. One time slice is around 300us.

2.2.19 Protocol Configuration 3 (1Bh)

The Default value is 00h.

The protocol configuration register 3 (PCON3) further specifies the general behavior of the reader device.

Protocol configuration 3 register							
Bit 7	Bit 6	Bit 5	Bit 4	Bit 3	Bit 2	Bit 1	Bit 0
SAK Extended ID	ReqA Extended ID	ISO14443 Type B settings			Page Read	RFU	Disable automatic ISO 14443-4 timeouts

2.2.19.1 Disable automatic ISO 14443-4 timeouts: bit 0 (default 0)

If Disable automatic ISO 14443-4 timeouts is set the automatic ISO 14443-4 timeouts are disabled. The timeouts specified with TMR registers are used.

2.2.19.2 Page read: bit 2 (default 0)

If set the continuous read mode retrieves the content of the tag instead of the serial number. The register Page Start (1Ch) defines the start block and the Page Number (1Fh) defines the number of blocks to be read.

**2.2.19.3 ISO14443 Type B Rx frame comms settings: bits 3-5 (default 00h)**

The bits 3 - 5 of this register define the communication settings of ISO 14443 B cards for the receiving frame.

Protocol Register 3: Bit 3 – 5		
Bit 5	Bit 4	Bit 3
NoRxEOF	NoRxEGT	NoRxSOF

Bit	Description
NoRxSOF	If set to 1 a missing SOF of the received data frame will be ignored.
NoRxEGT	If set to 1 a too short or too long EGT of the received frame will be ignored.
NoRxEOF	If set to 1 a missing EOF of the received data frame will be ignored.

2.2.19.4 ReqA Extended ID: bit 6 (default 0)

If set the Extended ID information for ISO14443 A tags replaces the cascade level information (1 byte) with Request A answer (2 bytes).

2.2.19.5 SAK Extended ID: bit 7 (default 0)

If set the Extended ID information for ISO 14443 A tags will include the SAK byte behind the serial number.

2.2.20 Modulation Conductance 0 (1Dh)

Default value is 05h.

The modulation defines the conductance of the output driver for the ISO 14443 B and SR176 tags modulation time. If modulation is set to 10%, also include ISO15693 tags. Use this to regulate the modulation index. Note that the conductance values are not linear! For further information, refer to the NXP documentation. [6]

2.2.21 Threshold (1Eh)

Default value is EBh

The higher nibble of the Threshold register defines the minimum accepted signal strength at the decoder input. The lower nibble of the Threshold register defines the collision level. For further information, refer to the NXP documentation. [6]

2.2.22 Protocol Configuration 4 (20h)

Default value is 00h.

The protocol configuration register (PCON4) specifies general behavior of the reader device.

Protocol configuration 4 register							
Bit 7	Bit 6	Bit 5	Bit 4	Bit 3	Bit 2	Bit 1	Bit 0
RFU	RFU	RFU	RFU	Huge data mode	CID Extended ID	WupA/B	Disable Read after Write

2.2.22.1 Disable Read after Write: bit 0 (default 0)

If set, the reader device will not make a read after write for the block write commands "w", "wb", "wd" and "wv".

If the read after write is deactivated, acknowledge from the write commands is a 00h byte instead of the written data.

2.2.22.2 WupA/B: bit 1 (default 0)

If set, the reader device will use WupA/B instead of ReqA/B during selection of an ISO 14443 tag. Supported commands are select, high-speed select and multi-select.

2.2.22.3 CID Extended ID: bit 2 (default 0)

If set, the extended ID information for ISO 14443 A/B tags will be extended with the CID information only for the high-speed select. The CID byte will be appended on the end of the output.

2.2.22.4 Huge data mode: bit 3 (default 0)

If set, the huge data mode of the transfer data command will be enabled only for ISO 14443 A/B. In huge data mode the option and length byte of the transfer data command will be turned off to enable larger data transmission.

In ASCII mode a trailing CR byte is mandatory.

2.2.23 CID (21h)

Default value is 00h.

The Card Identifier (CID) is used to activate multiple ISO 14443-4 cards at the same time. If only one tag at the same time is used this value should be left 0.

2.2.24 RxWait (22h)

Default value is 00h.

The RxWait value is a frame guard time until the receiver part will not receive any data. The value is given in bit-clock cycles. A value of 0 indicates the RxWait timing will be done with predefined values. For an air-speed of 106kBaud, the duration of one bit-clock cycle is ~9.4uS

2.2.25 Modulation conductance 1 (23h)

Default value is 00h.

This register is 1 of 4 different modulation conductance registers. The default used modulation conductance register is 0. For more information refer to Modulation Conductance 0 (1Dh), page 31 and Set target modulation conductance register, page 51.

2.2.26 Modulation conductance 2 (24h)

Default value is 00h.

This register is 1 of 4 different modulation conductance registers. The default used modulation conductance register is 0. For more information refer to Modulation Conductance 0 (1Dh), page 31 and Set target modulation conductance register, page 51.



2.2.27 Modulation conductance 3 (25h)

Default value is 00h.

This register is 1 of 4 different modulation conductance registers. The default used modulation conductance register is 0 For more information refer to Modulation Conductance 0 (1Dh), page 31 and Set target modulation conductance register, page 51.

2.2.28 User data (80h - EFh)

These registers are for free use.

2.3 Command Set

The following table describes all the commands of the reader device. Each command returns an answer to the host. Exceptions are mentioned explicitly. If fitted, the green LED acknowledges a successfully executed command and the red LED indicates an error.

Common Commands

Table 5 - Common Command Overview

Command	Description
'!'	Test continuous read / Check KTT upload status
'c'	Continuous read
','	Abort continuous read, refer to Continuous Read, page 36
'dg' / 'dn' / 'dr'	Set LED
'ds'	DES encryption / decryption of data
'g'	Get ID
'h'	High-speed select
'k'	Lock block
'm'	MultiTag select / tag list
'o&'	Switch on/off CTS
'o+a' / 'o+b' / 'o+d' / 'o+e' / 'o+i' / 'o+s' / 'o+v'	Include tag type
'o-a' / 'o-b' / 'o-d' / 'o-e' / 'o-i' / 'o-s' / 'o-v'	Exclude tag type
'oa' / 'ob' / 'od' / 'oe' / 'oi' / 'ot' / 'os' / 'ov'	Set tag type
'of'	Set configuration flags
'og'	Set configuration register
'om'	Set target modulation conductance register
'ox'	Reread all registers
'poff' / 'pon'	Antenna power off/on
'pr' / 'pw'	Read / write user port
'q'	Quiet
'ra'	Resend last answer
'r' / 'rb'	Read block
'rd'	Read data (multiple blocks)
'rp'	Read EEPROM register
's'	Select
'v'	Get version
'w' / 'wb'	Write block
'wd'	Write data (multiple blocks)
'wp'	Write EEPROM register
'x'	Reset
'y'	Field reset

**Table 6 - Card Specific Commands**

Command	Description
ISO 14443 Type A (MIFARE[®]) only commands	
'+'	Increment value block (credit)
'-'	Decrement value block (debit)
'='	Copy value block (backup)
'l'	Login (authenticate tag)
'rv'	Read value block
'wv'	Write value block
Key Management	
'ar'	Authenticate to reader
'ia'	Get key access rights
'it'	Get key status
'rt'	Reset key table
'ua'	Update key access rights
'uc'	Change key type
'uk'	Update key
my-d™ secure commands	
'l'	Check KTT upload status / Test continuous read
'*'	Abort KTT upload
'as'	Authenticate to sector
'ik'	Issue transponder key
'ut'	Prepare for KTT
'z'	my-d™ command

The following figure shows an overview of all error messages of the reader device.

Table 7 - Error Codes

Error Code	Description
'?'	Unknown command
'C'	Collision or CRC/MAC Error
'F'	General failure
'I'	Invalid value format, specified block does not match the value format
'N'	No tag in the field
'O'	Operation mode failure or file not selected
'R'	Command parameter out of range
'X'	Authentication failed

2.3.1 Common Commands

2.3.1.1 Test Continuous Read / Check KTT Upload Status

This command tests the state of the continuous read command and the state of the Prepare for KTT 'ut' command.

The test continuous read command is only valid in ASCII mode.

Command

Command	Data
'I'	None

Answer

Answer	Description
'I'	Continuous read mode is active.
00h	Keys from KTT successfully uploaded
01h	Error during key upload detected, upload aborted
02h	No KTT found, other tag was detected
FFh	Prepare for KTT is in awareness mode
'F'	Continuous read and Prepare for KTT is not active.
no response	Key uploading is in progress

2.3.1.2 Continuous Read

The reader device reads and displays serial numbers continuously while one or more tags remain in the field. This command stops if any character is sent to the reader module. The reader module returns the character 'S' (53h).

The reader supports different tag types at the same time. To increase the reading performance switch to a single tag mode. If more than one tag of the same type should be detected at the same time, the Multitag flag must be activated. The response data length depends on the tag type.

Command

Command	Data
'c'	None

Answer

Answer	Description
Data	Serial number (n bytes)
'N'	Error: No Tag in the field (only binary protocol)

2.3.1.2.1 Multitag continuous read mode

If the Multitag flag is set in the Protocol Configuration (PCON) register the reader reads multiple tags continuously.

2.3.1.2.2 Auto start



The continuous read mode is started automatically in ASCII mode. The auto start flag must be set in the PCON register.

2.3.1.2.3 Noisy Environment

If the Noisy Environment flag is set, the continuous read mode can only be aborted with the '.' character.

This is only valid in ASCII mode.

2.3.1.2.4 Binary mode

This command is fully supported in binary protocol mode except the test continuous read command and the noisy environment flag.

Do not use this command on bus system environment in binary mode, because the continuous read mode will take possession of the bus system.

2.3.1.2.5 Simple access control applications

Serial numbers are always sent plain. Data encryption is activated after a successful login.

For simple access control applications the use read-only blocks for the identification of the tag is recommended.

Reading any block (even the manufacturer block) of the transponder will increase your security.

2.3.1.2.6 LED activity

The LED stays green as long as a tag was found and goes dark if the tag is removed from the field.

2.3.1.3 Set LED

This command controls the LED activity. If the LED flag is set, the automatic LED function is switched off. The user can set the state of the LED manually.

Command

Command	Data
'dg'	None
'dr'	None
'dn'	None

Answer

Answer	Description
'DG' 'DR' 'DN'	String of LED state

Example

Command	Answer	Description
'dg'	DG	Switch on LED green, LED red off
'dr'	DR	Switch on LED red, LED green off
'dn'	DN	Switch off both LEDs

2.3.1.4 DES encryption / decryption of data

This command returns 8 bytes of encrypted / decrypted data.

Command

Command	Data
'ds'	Options (1 byte) Key (8/16 bytes) / Key Number (1 byte) Data (8 byte)

Answer

Answer	Description
Data	Encrypted / Decrypted data (8 bytes)

Option byte

Option byte							
Bit 7	Bit 6	Bit 5	Bit 4	Bit 3	Bit 2	Bit 1	Bit 0
RFU	RFU	RFU	RFU	RFU	Encode	Key Length	Key Index

Key Index

If the Key Index is set, the command only needs the key number (1 byte) instead of the key (8/16 bytes).

The key number corresponds to the key number used in the key management.

Key Length

If the Key Length is set, the command uses the TDES algorithm with 16-byte key.

If cleared, the command uses the DES algorithm with 8-byte key.

If key index is used the key length flag is valid.

Encode

Setting this flag encodes the data.

Clearing this flag decodes the data.



2.3.1.5 Get ID

This command returns the station ID of the reader device. The answer is time slotted to enable the detection of all devices in party line mode.

The station ID has only effect in binary mode.

Command

Command	Data
'g'	None

Answer

Answer	Description
Data	Station ID of the reader device (1 byte)

2.3.1.5.1 Time slotted answer

In party line mode, more than one reader can be used simultaneously. The time slotted answer allows separating in time the answers from all connected devices. The station ID is used to determine the correct time slot.

The reader supports up to 254 unique time slots. The following formula calculates the duration of one time slot (only one baud rate is supported per party line):

$$T_0[s] = \frac{10}{\text{Baudrate}} * 6$$

The following figure shows the timing diagram of time slotted answers.

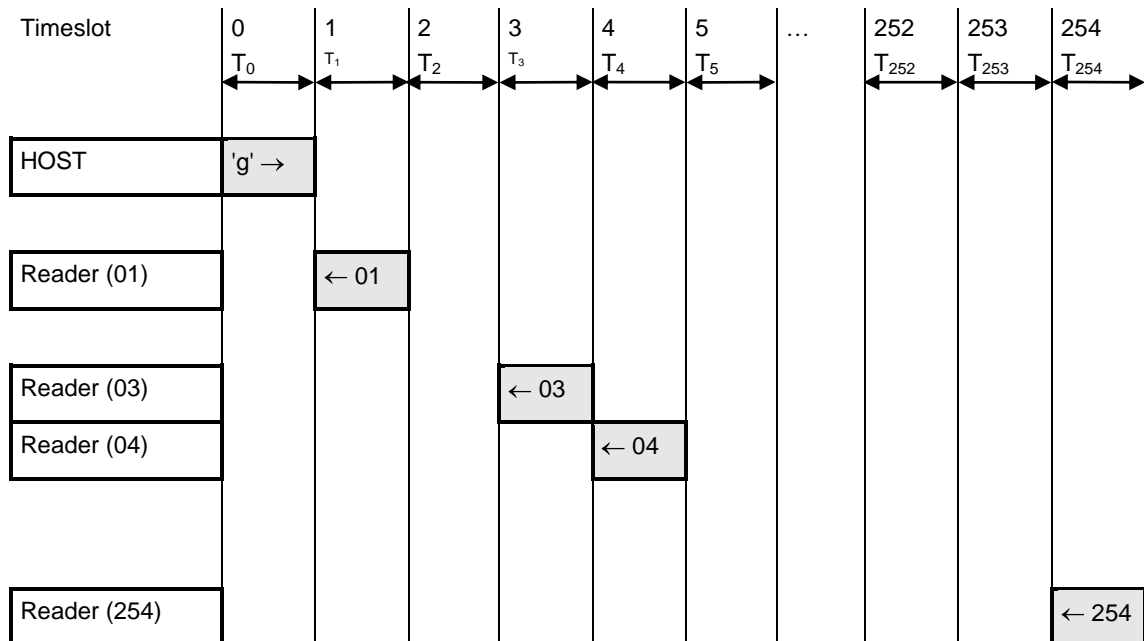

2.3.1.5.2 Binary Protocol Version 2

This command never sends version 2 binary frames.

2.3.1.6 High-speed select

This command selects a card in the antenna field (according to the selection criteria) or prepares a multi-select command, switches to high baud rates and enables 256-byte frames. If execution is successful, the command returns the UID of the selected card and the used baud rate. The reader automatically detects the maximum frame size of the card. The reader also tries to communicate to the transponder with the specified baud rate. If no communication is possible, the reader will automatically decrease the speed to the next lower value.

In synchronous mode the up and downlink speed are identical.

In asynchronous mode the up and downlink speed can be different.

This command can also force the reader to the communication speed and frame size of the tag to the specified values. This is only needed if the high-speed select is done manually with the transfer command.

Command

Command	Data
'h'	<p>Option byte (1 byte)</p> <p>synchronous mode</p> <p>00h ... select a single card with 106kBaud 02h ... select a single card with 212kBaud 04h ... select a single card with 424kBaud 08h ... select a single card with 848kBaud</p> <p>10h ... prepare next multi-select for 106kbaud 12h ... prepare next multi-select for 212kbaud 14h ... prepare next multi-select for 424kbaud 18h ... prepare next multi-select for 848kbaud</p> <p>20h ... forces reader to 106kBaud 22h ... forces reader to 212kBaud 24h ... forces reader to 424kBaud 28h ... forces reader to 848kBaud</p> <p>tag size</p> <p>30h – 38h ... force tag frame size</p> <p>asynchronous mode</p> <p>80h ... select a single card with 106kBaud 82h ... select a single card with 212kBaud 84h ... select a single card with 424kBaud 88h ... select a single card with 848kBaud</p> <p>90h ... prepare next multi-select for 106kbaud 92h ... prepare next multi-select for 212kbaud 94h ... prepare next multi-select for 424kbaud 98h ... prepare next multi-select for 848kbaud</p> <p>A0h ... forces reader to 106kBaud from tag to reader A2h ... forces reader to 212kBaud from tag to reader A4h ... forces reader to 424kBaud from tag to reader A8h ... forces reader to 848kBaud from tag to reader</p>



Command	Data
	B0h ... forces reader to 106kBaud from reader to tag B2h ... forces reader to 212kBaud from reader to tag B4h ... forces reader to 424kBaud from reader to tag B8h ... forces reader to 848kBaud from reader to tag

Answer

Answer	Description
Data (n bytes) + frame size and baud rate (1byte)	Serial number + frame size used and baud rate
'F'	Error: General failure
'N'	Error: No Tag in field [addressed tag not present or not responding]

Note: If the tag does not support ISO 14443 part 4 F0h will return after serial number instead of used frame size/baud rate.

Examples

High-speed select

Command	Description
h08	1234567890ABCD84 Select the card with UID 1234567890SABCD. The card supports a 256-byte frame size and 424kBaud on the air interface.

High-speed multi-select

Command	Description
h18 m1234567890ABCD<CR>	Prepare next multi-select for 848kBd 1234567890ABCD84 Select the card with UID 1234567890SABCD. The card supports a 256-byte frame size and 424kBaud on the air interface.

2.3.1.6.1 Answer from 0xh and 1xh

The lower nibble contains the baud rate used for the air interface.

Baud Rate	Description
x0	106kBaud
x2	212kBaud
x4	424kBaud
x8	848kBaud

The higher nibble contains the frame size used for the air interface.

Frame Size	Description
0x	16 Bytes
1x	24 Bytes
2x	32 Bytes

Frame Size	Description
3x	40 Bytes
4x	48 Bytes
5x	64 Bytes
6x	96 Bytes
7x	128 Bytes
8x	256 Bytes

2.3.1.6.2 Answer from 8xh

The lower nibble contains the baud rate used for the air interface.

The value for the baud rate is XORed with the used up and downlink speed.

Baud Rate	Description
x1	106kBaud
x2	212kBaud
x4	424kBaud
x8	848kBaud

The higher nibble contains the frame size used for the air interface.

Frame Size	Description
0x	16 Bytes
1x	24 Bytes
2x	32 Bytes
3x	40 Bytes
4x	48 Bytes
5x	64 Bytes
6x	96 Bytes
7x	128 Bytes
8x	256 Bytes

2.3.1.6.3 Answer from 2xh, 3xh, 9xh, Axh and Bxh

The option byte is returned as the answer.

2.3.1.6.4 Select a single tag

No previous continuous read is required. The command executes an automatic field reset.



2.3.1.6.5 Extended ID

See Protocol Configuration 3 (1Bh), page 30 for more information on Extended ID.

The RATS answer is inserted between the serial number and baud rate / frame size byte for ISO14443 A tags.

2.3.1.6.6 Multiple tags

This command with parameter 1xh prepares the next multi-select command as a high-speed select. Any other command will disable the preparation.

2.3.1.6.7 RATS Guard Time SFGT

A high-speed select with parameters 0xh and 1xh automatically waits the SFGT guard time received from the tag before sending the PPS command.

2.3.1.7 Lock Block

This command locks a block permanently. Only SR176 and ISO 15693 tags are supported.

Command

Command	Data
'k'	Block address (1 byte)

Answer

Answer	Description
Data	'K' + page address
'F'	Error: Lock failure
'N'	Error: No tag in field [addressed tag not present or not responding]
'O'	Error: Operation mode failure [tag is neither SR176 or ISO 15693 compliant]
'X'	Error: Block already locked

Example

Command	Description
k05	K05 Lock block 05.

2.3.1.7.1 Apply settings

After locking a block permanently, the tag needs to be selected for the settings to apply.

2.3.1.8 Multi-Tag Selection / List

This command detects several tags at the same time. It replaces the fast select command ('s') in multiple tag surroundings. The Multi-Tag List command lists all tags with their serial numbers. Use the Multi-Tag Select command to select a single tag. Each tag has to be selected separately.

Command

Command	Data
'm'	Serial number (n bytes) <CR> (1 byte)

Answer

Answer	Description
Data	serial number
'N'	Error: No Tag in the field [addressed tag not present or not responding]

Example

Command	Description
m<CR>	04E9E700000000 → first card 34030F07 → second card 02 → number of detected tags
m04E9E700000000<CR>	Select card with its serial number

2.3.1.8.1 Multi-tag list

Sending a <CR> as the first parameter, the reader returns a list of all tags present in the antenna field. In the end the total number of tags detected is returned.

2.3.1.8.2 Reading distance

Each card needs a specific amount of power. The reader always provides the same power level. Therefore, the reading distance will decrease if more tags are present. Basically, the reading distance depends on the tag, the antenna and the tuning of the antenna.

2.3.1.8.3 Multi-tag select

Using the serial number with <CR> as parameter, the corresponding tag will be selected. High-level interactions can be performed addressing only this card. All other tags remain silent.

2.3.1.8.4 Multi-tag reset

The antenna field reset can be deactivated with the Protocol configuration 2 register.

By suppressing the antenna field reset, it is possible to detect only new tags in the antenna field.

CAUTION: Possibly, ISO 15693 tags are interfered from ISO14443 type B and SR 176 tags. In this case, the ISO 15693 tag always answers on a multi list command even if there was no previous field reset. In this case, deactivate ISO 14443 B and SR 176 tags.

2.3.1.8.5 Maximum number of tags

The maximum number of tags in the antenna field is limited to 64 and by the physical characteristics of the antenna.

2.3.1.8.6 LED activity

The LED stays green as long as a tag was found and goes dark if the command is finished.



2.3.1.9 Switch on/off CTS

This command switches on/off the usage of CTS. If switched on, the reader only answers if CTS is low. Ensure the hardware supports CTS before using this command

Command

Command	Data
'o&'	Data (1 byte) 00h = off; 01h = on

Answer

Answer	Description
Data (1 byte)	New status of CTS 00h = off; 01h = on

2.3.1.10 Include Tag Type

This command includes a specific tag type to those addressed by the reader device.

Command

Command	Data
'o+'	Tag type (1 byte)

Answer

Answer	Description
'O+' + tag type (1 byte)	Command code + String of tag type

Tag type character

Refer to Set tag type, page 47.

Example

Command	Description
o+a	Include ISO14443-A to the tag types addressed by the reader



2.3.1.11 Exclude tag type

This command excludes a specific tag type from being addressed by the reader device.

Command

Command	Data
'o'	Tag type (1 byte)

Answer

Answer	Description
'O' + tag type (1 byte)	Command code + String of tag type

Tag type character

Refer to Set tag type, page 47.

Example

Command	Description
o-a	Exclude ISO14443-A from the tag types addressed by the reader



2.3.1.12 Set tag type

This command sets up the reader for a specific tag type. The continuous read function will speed up because only this type of tag is addressed. After a reset, the reader starts as defined in its start-up configuration.

Command

Command	Data
'o'	ISO type (1 byte) 'a' ... ISO 14443 Type A 'b' ... ISO 14443 Type B 'd' ... ICODE UID 'e' ... ICODE EPC 'i' ... ICODE 's' ... SR176 't' ... activate all tags 'v' ... ISO 15693

Answer

Answer	Description
'OA' 'OB' 'OD' 'OE' 'OI' 'OS' 'OT' 'OV'	String of tag type

Example

Command	Description
oa	Sets the reader device to address ISO14443-A type tags.

Innovision Jewel tag

Innovision Jewel tag is part of ISO 14443 Type A. It can not be separately switched on/off.

2.3.1.13 Set Configuration Flags

This command allows setting some configuration flags just in time; no reset is needed. The values are not stored in the EEPROM; therefore, the changed values are not available after a reset.

Command

Command	Data
of	flag type (1 byte) data (1 byte)

Answer

Answer	Description
Data (1 byte)	Current state of changed flag.
'R'	Error: Out of range

Example

Command	Description
of 01 01	Answer: 01 Enables the New Serial Mode flag.



Flag Types

The following table shows the Flag Type with its corresponding flag from the specified Protocol Configuration Register.

Table 26 Flag Type with corresponding flag

Flag Type	Corresponding Flag	Protocol Register	Configuration	Valid values
00h	Multitag	1		00 / 01
01h	New Serial Mode	1		00 / 01
02h	LED	1		00 / 01
03h	Single Shot	1		00 / 01
04h	Extended Protocol	1		00 / 01
05h	Extended ID	1		00 / 01
06h	Disable Multitag Reset	2		00 / 01
07h	Noisy Environment	2		00 / 01
08h	Reset Recovery Time Multiplier	2		00 ... 03
09h	Enable ISO14443 B Anti-collision	2		00 / 01
0Ah	Disable ISO14443-4 Error Handling	2		00 / 01
0Bh	Disable automatic ISO14443-4 timeouts	3		00 / 01
0Dh	Page Read	3		00 / 01
0Eh	NoRxSOF	3		00 / 01
0Fh	NoRxEGT	3		00 / 01
10h	NoRxEOF	3		00 / 01
11h	ReqA Extended ID	3		00 / 01
12h	Disable Read after Write	4		00 / 01
13h	SAK Extended ID	3		00 / 01
14h	WupA/B	4		00 / 01
15h	CID Extended ID	4		00 / 01
16h	Internal use / Do not change			

2.3.1.13.1 Out of range failure 'R'

The entered flag type is out of range.

2.3.1.14 Set Configuration Register

This command allows setting some configuration registers just in time; no reset is needed. The values are not stored in the EEPROM; therefore the changed values are not available after a reset.

Command

Command	Data
Og	Register type (1 byte) data (1 byte)

Answer

Answer	Description
Data (1 byte)	Current state of changed register.
'R'	Error: Out of range [entered register value is out of range]

Example

Command	Description
og0450	Answer: 50 Sets the Reset Recovery Time to 50h.

Register Types

The following table shows the Register Type with its corresponding register.

Table 8 - Register Type with Corresponding Register

Register Type	Corresponding Register
00h	Single shot time-out value
01h	TMR low
02h	TMR high
03h	Reset Off Time
04h	Reset Recovery Time
05h	ISO 14443A Selection Time-out
06h	ISO 14443B Selection Time-out
07h	SR176 Selection Time-out
08h	AFI
09h	Modulation conductance
0Ah	Threshold
0Ch	Page Read Start
0Dh	Page Read Number
0Eh	Command Guard Time
0Fh	CID
10h	Internal use / Do not change



2.3.1.15 Set target modulation conductance register

This command allows switching to a different modulation conductance register. On startup, modulation conductance register 0 is used.

When more than one antenna is used, it may be necessary to use different modulation conductance values for different antennas. Switching registers does not require knowledge of the actual values used.

Ensure that Modulation Conductance registers 1-3 are initialised before using this feature.

Command

Command	Data
om	Target modulation conductance register (1 byte) Valid range 00h – 03h

Answer

Answer	Description
Data (2 bytes)	Target modulation conductance register (1 byte); register value (1 byte)
'R'	Error: Out of range [selected register is out of range]

2.3.1.16 Reread all registers

This command rereads and applies all register settings.

Command

Command	Data
Ox	none

Answer

Answer	Description
Data (3 bytes)	'X' + new protocol + new baud rate

Example

Command	Description
Ox	Answer: X0106 binary protocol and 460800 baud active

New protocol

00h means ASCII and 01h means binary protocol.

New baud rate

Values of 00h-06h are valid. For baud rate values refer to BAUD, Baud Rate Control Register (0Ch), page 25.

2.3.1.17 Antenna power on/off

This command controls the antenna power. It can be used to decrease the power consumption of the reader.

Command

Command	Data
'pon'	Switch reader on
'poff'	Put reader in standby mode

Answer

Answer	Description
'P'	Positive acknowledge

Example

Command	Description
Poff	Put reader in standby mode

2.3.1.17.1 Power off

The reader enters standby mode. Power consumption is decreased. All tags in the antenna field are powered off and reset. Standby mode is only entered manually.

To switch off the whole unit, pin 16 (Enable) has to be set to logic low.

2.3.1.17.2 Power on

The reader leaves standby mode and is ready for the next command. Sending a tag command (i.e. select, continuous read) the reader is powered up.

2.3.1.18 Read/Write User Port

This command sets or reads the state of the user port (pin 14) of the OEM reader device. The port is set either as output or as input. If set to output, see notes in Jumper 2 Details, page 14 regarding current limiting to prevent reader damage.

Command

Command	Data
'pr'	None
'pw'	State of user port (1 Byte)

Answer

Answer	Description
Data	State of user port (1 Byte)
'C'	Error: Error correction fails
'F'	Error: Transmission Error / No answer received

**Example**

Command	Description
Pr	Reads user port
pw01	Sets user port state to high

2.3.1.18.1 Read port

The port read command returns the current state of the USER port.

Port state	Description
00h	USER port is low
01h	USER port is high

2.3.1.18.2 Write port

If user port is used as an output, a 1k Ω resistor has to be integrated into the wire. Otherwise the reader device can be damaged.

Port state	Description
00h	Sets USER port to low
01h	Sets USER port to high
02h – 7Fh	RFU
80h – FFh	Sends a serial data frame and checks the received frame

Sending a Data Frame

If the highest bit (MSB) is set in the State of the User Port, the command sends a serial data frame out the USER port.

The frame includes a start bit, 8 data bits, parity bit and a stop bit.

Table 9 - Sending Serial Data Frame

Transmit Frame	Description
Low	Start bit
Low	RFU
Data Bit 6	State of the User Port Bit 6
Data Bit 5	State of the User Port Bit 5
Data Bit 4	State of the User Port Bit 4
Data Bit 3	State of the User Port Bit 3
Data Bit 2	State of the User Port Bit 2
Data Bit 1	State of the User Port Bit 1
Data Bit 0	State of the User Port Bit 0
Parity Bit	Even Parity Bit
High	Stop Bit

After 2ms Guard Time the answer should be received on the User Port otherwise an error is returned.

Table 10 - Receiving Serial Data Frame

Receive Frame	Description
Low	Start bit
Error Bit	If set, an error was detected.
Data Bit 6	State of the User Port Bit 6
Data Bit 5	State of the User Port Bit 5
Data Bit 4	State of the User Port Bit 4
Data Bit 3	State of the User Port Bit 3
Data Bit 2	State of the User Port Bit 2
Data Bit 1	State of the User Port Bit 1
Data Bit 0	State of the User Port Bit 0
Parity Bit	Even Parity Bit
High	Stop Bit

If the Error bit is set or the Parity Bit is not correct, the Write User Port command returns an error code.

2.3.1.19 Quiet

This command sets a selected tag into halt state. Only ISO14443 A+B and SR176 tags are supported.

Command

Command	Data
'q'	None

Answer

Answer	Description
'Q'	Halt state successfully set.
'N'	Error: No Tag in the field [addressed tag not present or not responding]

2.3.1.19.1 ISO 14443 Type A

With ISO14443-3 Type A tags, the Quiet command always answers with 'Q' because the halt command does not send any acknowledge.

In Part 4 a 'Deselect' command will be performed.

2.3.1.19.2 ISO 14443 Type B

Some ISO14443 Type B tags do not support this command or do not respond. 'Quiet' is an ISO 14443-4 command, so it will work only if the 'Deselect' command is supported by the corresponding transponder.

2.3.1.19.3 SR176

With SR176 tags the Quiet command always answer with 'Q' because the completion command does not send any acknowledge.



2.3.1.20 Resend Last Answer

This command resends the last answer from the internal serial buffer of the reader.

Command

Command	Data
'ra'	Resend last answer

2.3.1.21 Read block

This command reads a data block on a card. The size of the returned data depends on the tag used. The block address range depends on the tag as well.

Command

Command	Data
'r'	Block address (1 byte), valid range 00h – 40h
'rb'	Block address (1 byte)

Answer

Answer	Description
Data	data block (depends on tag type)
'F'	Error: read failure [bad data or address range error]
'N'	Error: No tag in field [addressed tag not present or not responding]
'O'	Error: Operation mode failure
'R'	Error: Out of range

Example

Command	Description
rb05	Reads block 05.

2.3.1.21.1 Operation mode failure 'O'

The presented tag is not ISO14443 type A, SR 176, ICode, ICode-UID and ISO 15693 compliant. For ISO 14443 type A only MIFARE tags are supported.

This error also appears if the reader is not correctly configured.

2.3.1.21.2 Out of range failure 'R'

The block address of the 'r' command is higher than 40h.

The block address of the 'r' command conflicts with other commands, therefore the block address has to be limited to 40h.

Use the 'rb' command instead.

2.3.1.22 Read data (multiple blocks)

This command reads multiple data blocks on a card. The size of the returned data depends on the tag used. The block address range depends on the tag as well.

Command

Command	Data
'rd'	Start block address (1 byte) Number of blocks to read (1 byte)

Answer

Answer	Description
Data	data block (depends on tag type)
'F'	Error: read failure [bad data or address range error]
'N'	Error: No tag in field [addressed tag not present or not responding]
'O'	Error: Operation mode failure

Example

Command	Description
rd0504	Reads 4 blocks starting with block 05.

2.3.1.22.1 Operation mode failure 'O'

The presented tag is not ISO14443 type A, SR 176, ICode or ISO 15693 compliant.

For ISO 14443 type A only MIFARE tags are supported.

2.3.1.23 Read reader EEPROM

This command reads the internal reader EEPROM. It contains all start-up parameters and the device ID. Changes in the start-up settings will only go into effect after a reset of the device.

Command

Command	Data
'rp'	EEPROM address (1 byte) 00h ... EFh

Answer

Answer	Description
Data	EEPROM data (1 byte)
'R'	Error: Out of range failure [entered address is not valid]

Example

Command	Description
rp0B	Reads protocol configuration register.



2.3.1.24 Select

This command selects a single card in the antenna field. It can only be used in single tag mode. If successfully executed, the command returns the UID of the selected card. The reader detects the length of the UID automatically.

Command

Command	Data
's'	None

Answer

Answer	Description
Data	serial number
'N'	Error: No Tag in the field [addressed tag not present or not responding]

Example

Command	Description
S	1234567890ABCD Select the card with UID 1234567890SABCD.

2.3.1.24.1 Select a single tag

No previous continuous read is required. The command executes an automatic field reset.

2.3.1.24.2 Extended ID

See Protocol Configuration 1 (0Bh), page 24 for more information on Extended ID.

2.3.1.24.3 Multiple tags

This command is designed for fast access of a single tag in the field. If multiple cards are used the 'm' instruction has to be used instead.

2.3.1.25 Get Version

This command returns the current version of the reader module.

Command

Command	Data
'v'	None

Answer

Answer	Description
'MultilSO 1.0' + <CR> + <LF>	ASCII Mode
02 00 0C 4D 75 6C 74 69 49 53 4F 20 31 2E 30 1F 03	Binary Mode

Example

Command	Description
V	'MultilSO 1.0' Version of the reader module

2.3.1.26 Write block

This command writes data to a block.

Command

Command	Data
'w'	Block address (1 byte), valid range 00h – 40h Data (n bytes)
'wb'	Block address (1 byte) Data (n bytes)

Answer

Answer	Description
Data	Data block (depends on tag type)
'F'	Error: Write failure [bad transmission conditions or address range error]
'N'	Error: No tag in field [addressed tag not present or not responding]
'O'	Error: Operation mode failure
'R'	Error: Out of range

Example

Command	Description
wb0511223344	Writes data 11223344 on block 05.

2.3.1.26.1 Operation mode failure 'O'

The presented tag is not ISO14443 type A, SR 176, ICode, ICode-UID and ISO 15693 compliant. For ISO 14443 type A only MIFARE tags are supported.

2.3.1.26.2 Out of range failure 'R'

The block address of the 'w' command is higher than 40h.

The block address of the 'w' command conflicts with other commands, therefore the block address has to be limited to 40h.

Use the 'wb' command instead.

2.3.1.26.3 Disable Read after Write

A read is done automatically after every write to ensure correct writing.

If the "disable Read after Write flag" is set no read is done, and the returned data is a 00h byte in case of successfully written data.



2.3.1.27 Write data (multiple blocks)

This command writes multiple blocks to a card.

Command

Command	Data
'wd'	Start block address (1 byte) Number of blocks (1 byte) Data (n bytes)

Answer

Answer	Description
Data	Data block (depends on tag type)
'F'	Error: Write failure [bad transmission conditions or address range error]
'N'	Error: No tag in field [addressed tag not present or not responding]
'O'	Error: Operation mode failure

Example

Command	Description
wd050211223344556 67788	Writes data 11223344 on block 05 and 55667788 on block 06.

2.3.1.27.1 Operation mode failure 'O'

The presented tag is not ISO14443 type A, SR 176, ICode or ISO 15693 compliant.

For ISO 14443 type A only MIFARE tags are supported.

2.3.1.27.2 Disable Read after Write

A read is done automatically after every write to ensure correct writing.

If the "disable Read after Write flag" is set no read is done, and the returned data is a 00h byte in case of successfully written data.

2.3.1.28 Write EEPROM

Writes to the internal reader EEPROM. It contains all start-up parameters and the device ID. Changes to the start-up settings will only go into effect after a reset of the device.

Command

Command	Data
'wp'	Address (1 byte), valid range 0Ah - EFh Data (1 byte)

Answer

Answer	Description
Data	EEPROM data (1 byte)
'F'	Error: Read after write failure
'R'	Error: Out of range failure [entered address exceeds the address range]

Example

Command	Description
wp0A01	Set EEPROM address 0A (Station ID) to 01h

2.3.1.29 Reset

This command executes a power on (software) reset. New configuration settings will be loaded. It resets all tags in the antenna field.

Command

Command	Data
'x'	None

Answer

Answer	Description
'MultiISO 1.2' + <CR> + <LF>	ASCII Mode
None	Binary Mode

2.3.1.29.1 Disable Start-up Message

If the start-up message is disabled in the protocol configuration register 2, the ASCII mode does not respond with the version of the reader.

2.3.1.29.2 Reset Timing

The power up timing depends on environmental conditions such as voltage ramp up. For handheld devices the timing can vary based on the charge state of the battery.



2.3.1.30 Field Reset

The field reset switches off the antenna field for the specified duration. All tags need a certain amount of time to initialize before a command can be processed. The second byte specifies the field recovery time.

Command

Command	Data
'y'	Off time in milliseconds (1 byte) Field recovery time in milliseconds (1 byte)

Answer

Answer	Description
'Y'	After the field reset the reader sends back a 'Y' to acknowledge the command.

2.3.2 ISO 14443 Type A (MIFARE[®]) only commands

2.3.2.1 Increment value block (credit)

Increments a value block with a defined value. A read is done automatically after a write to verify data integrity. The command fails if the source block is not in value block format. A previous login is needed to access a block.

Command

Command	Data
'+'	Block # (1 byte); Value (4 bytes)

Answer

Answer	Description
Data	Value (4 bytes)
'I'	Error: value block failure
'F'	Error: increment failure or inability to read after write
'N'	Error: No tag in field [addressed tag not present or not responding]
'O'	Error: Operation mode failure [tag is not ISO14443 type A compliant]

Example

Command	Description
+0400000001	Adds 1 to value block 4
+0500000100	Adds 256 to value block 5

2.3.2.1.1 No value block 'I'

Specified block does not match the value format. The value block is corrupted. A backup block can be used to restore the correct value.

2.3.2.2 Decrement value block (debit)

Decrements a value block with a defined value. A read is done automatically after the write to verify data integrity. The command fails if the source block is not in value block format. A previous login is needed to access a block.

Command

Command	Data
'L'	Block (1 byte) Value (4 bytes)

Answer

Answer	Description
Data	Value (4 bytes)
'I'	Error: value block failure
'F'	Error: decrement failure or inability to read after write
'N'	Error: No tag in field [addressed tag not present or not responding]
'O'	Error: Operation mode failure [tag is not ISO14443 type A compliant]

Example

Command	Description
-0400000001	Subtract 1 to value block 4
-0500000100	Subtract 256 to value block 5

2.3.2.2.1 No value block 'I'

Specified block does not match the value format. The value block is corrupted. A backup block can be used to restore the correct value.

2.3.2.3 Copy value block (backup)

Copies a value block to another block of the same sector. A read is done automatically after the write to ensure data integrity. Used for backup and error recovery. A previous login is needed to access a block.

Command

Command	Data
'='	Source block (1 byte) Target block (1 byte)

Answer

Answer	Description
Data	New value of target block (4 bytes).
'I'	Error: value block failure
'F'	Error: copy failure or inability to read after write
'N'	Error: No tag in field [addressed tag not present or not responding]
'O'	Error: Operation mode failure [tag is not ISO14443 type A compliant]



Example

Command	Description
=0405	Copy value block 4 to block 5
=0506	Copy value block 5 to block 6

2.3.2.3.1 Target block

The target block does not need to be a valid value block. If the source block is not in value format, the command fails.

2.3.2.3.2 No value block 'I'

Source value block is not in a valid value block. The value block is corrupted. A backup block can be used to restore the correct value.

2.3.2.4 Login (authenticate tag)

Performs an authentication in order to access one sector of a MIFARE card. Only one sector can be accessed at a time.

Command

Command	Data
'I'	Sector (1 byte), valid range 00h - 3Fh Key type (1 byte) AAh authenticate with key type A FFh authenticate with key type A, transport key FFFFFFFFFh BBh authenticate with key type B 10h ... 2Fh authenticate with key type A using stored key (00h ... 1Fh) 30h ... 4Fh authenticate with key type B using stored key (00h ... 1Fh) Key (6 bytes) / <CR> (1 byte), optional By transmitting <CR> instead of the keydata authentication is done with manufacturer's transport keys (A0A1A2A3A4A5h, B0B1B2B3B4B5h, FFFFFFFFFFh).

Answer

Answer	Description
data	Login status (1 byte)
'L'	Login success
'F'	Error: General failure
'N'	Error: No tag in field [addressed tag not present or not responding]
'O'	Error: Operation mode failure [tag is not ISO14443 type A compliant]
'R'	Error: Out of range [entered key type or the sector is out of range]
'X'	Error: Authentication failed

**Example**

Command	Description
I02AA<CR>	Authenticate for sector 2, using the transport key A (A0A1A2A3A4A5h, key type A)
I3FBB<CR>	Authenticate for sector 63, using the transport key 2 (B0B1B2B3B4B5h, key type B)
I04FF<CR>	Authenticate for sector 4, using the transport key 3 (FFFFFFFFFFFh, key type A)
I0FAAFFFFFFFFFFFF	Authenticate for sector 15, using key FFFFFFFFFFFFh, key type A
I0E14	Authenticate for sector 14, using EEPROM key 4, key type A
I0530	Authenticate for sector 5, using EEPROM key 0, key type B
I0732	Authenticate for sector 7, using EEPROM key 2, key type B
I0110	Authenticate for sector 1, using EEPROM key 0, key type A
I0ABBFF12FFFFFF35	Authenticate for sector 10, using key FF12FFFFFF35h, key type B

2.3.2.4.1 <CR>

Three transport keys are implemented to access cards quickly.

By transmitting <CR> instead of the key, the reader module uses the transport keys for the login procedure.

Command	Description
LxxAA<CR>	Authenticate for sector xx, using the transport key 1 (A0A1A2A3A4A5h, key type A)
LxxBB<CR>	Authenticate for sector xx, using the transport key 2 (B0B1B2B3B4B5h, key type B)
LxxFF<CR>	Authenticate for sector xx, using the transport key 3 (FFFFFFFFFFFh, key type A)

2.3.2.4.2 Login with key data from EEPROM

Each key stored in the reader EEPROM can be used as type A or type B key. To use a key as type A, the value 10h must be added to the key index. 30h must be added to use a key as type B.

2.3.2.4.3 Usage of key A, key B

MIFARE cards support two different crypto keys for each sector. Each key is 32 bits long and is stored in the sector trailer (last block of the sector) on the card. It is possible to set different access rights for each key.



2.3.2.5 Read value block

Reads a value block. The command checks if data is in value block format. The read value block command needs a successful login.

Command

Command	Data
'rv'	Value block (1 byte)

Answer

Answer	Description
Data	Read value (4 bytes)
'F'	Error: General failure due to bad transmission conditions or address not authenticated
'I'	Error: value block failure
'N'	Error: No tag in field [addressed tag not present or not responding]
'O'	Error: Operation mode failure [tag is not ISO14443 type A compliant]

Example

Command	Description
rv04	Reads value of block 4.

2.3.2.5.1 No value block 'I'

The value read back after the write value command is not a value block. Data was written corruptly.

2.3.2.6 Write value block

This command formats a block as a value block containing a 32-bit value. Value blocks need a complete 16-byte block due to redundant storage. A successful login is required to run the command.

Command

Command	Data
'wv'	Value block (1 byte); Value (4 bytes)

Answer

Answer	Description
Data	Written value (4 bytes)
'I'	Error: value block failure
'F'	Error: write failure due to bad transmission conditions or address not authenticated
'N'	Error: No tag in field [addressed tag not present or not responding]
'O'	Error: Operation mode failure [tag is not ISO14443 type A compliant]

Example

Command	Description
wv05010055EF	Writes value 010055EFh to block 5.



2.3.2.6.1 Invalid value 'I'

The value read back after the write value command is not a value block. The data written was corrupt.

2.3.2.6.2 Writing values

The write value block command is designed to create blocks in value format. This command requires write access to the specified block. Using this instruction for ticketing operations is not recommended. For ticketing applications, special instructions (Increment/Decrement/Copy) are available.

2.3.2.6.3 Disable Read after Write

A read is done automatically after every write to ensure correct writing.

If the "disable Read after Write flag" is set no read is done, and the returned data is a 00h byte in case of successfully written data.

2.3.3 Key Management

The Key Management is able to store up to 32 keys and is also able to manage 3 different key types.

If no key is available to login into the reader, it is possible to reset the key table without any authentication.

Key type	Description
01	my-d™ secure key
02	DES key
03	MIFARE key

2.3.3.1 Authenticate to reader

This command logs into a reader. Only my-d™ secure and DES keys are allowed to login into reader. After successful log in the key table of the reader can be changed. The authentication does 2 two-pass authentications, defined in ISO 9798 part 2, within two steps. Following commands need a prior log in:

- Update key
- Update key access rights
- Change key type
- Reset key table

Command

Command	Data
Step 1: 'ar'	Option x1h (1 byte) Key type (1 byte) Key index (1 byte)
Step 2: 'ar'	Option x2h (1 byte) Random number key Management (8 bytes) MAC key Management (8 bytes)



Answer

Answer	Description
Step 1	Random number reader (8 bytes)
Step 2	MAC reader (8 bytes)

Option

The option byte defines the authentication step and type of authentication.

Bit	Description
0 – 1	Authentication Steps 0: Log out 1: Step 1 2: Step 2
2 – 6	RFU
7	Authentication Algorithm 0: 2 two pass authentications 1: RFU

Key index

The key index of Step 1 points to a valid key with the access rights to login into the reader.

The key index is zero based.

Log out

It is possible to log out with Authentication Step 0.

Default Keys

The following keys are default:

Key Type	Key
my-d™	01020407080B0D0E10131516191A1C1Fh Default Master key
DESFire	00000000000000000000000000000000h
MIFARE®	A0A1A2A3A4A5h
MIFARE®	B0B1B2B3B4B5h
MIFARE®	FFFFFFFFFh

Two-Pass Authentication Flow Diagram

Host		Reader
1. Start Authentication Step 1	StartAuth →	
		2. Generate Random number RndRdr
	← RndRdr	3. Reply Random number
4. Generate Random number RndH		
5. Calculate the MAC of the key management MacH = Enc(RndRdr)		
6. Transmit Random number and MAC: RndKm,MacH	RndKm,MacH →	
		7. Check the received MacH RndRdr = Dec(MacH)
		8. Calculate the MAC of the reader MacRdr = Enc(RndH)
	← MacRdr	9. Reply MAC
10. Check the received MacRdr RndH = Dec(MacRdr)?		

2.3.3.2 Get Key Access Rights

Command

Command	Data
'ia'	Key type (1 byte); Key index (1 byte)

Answer

Answer	Description
Data	Access rights (2 bytes). Higher Byte is send first

Access Rights

Only the default master key has all access rights. New keys got the default value 0000h.

Bit	Description
0	Allow Add Key
1	Allow Update Key
2	Allow Delete Key
3	Allow Reset Key table
4 – 7	RFU
8	RFU (Disable Serial Encryption)
9	Disable Authentication Tag
10	Allow Authentication Reader
11	Allow Changing Access rights
12	Allow Key Type changing
13	Allow 'ds' encryption
14 – 15	RFU



2.3.3.3 Get key status

This command reports the key status of the reader. The reader lists for each key the key information. This command is used to inform the key management about the key status. The first byte of the response lists the number of stored keys.

Command

Command	Data
'it'	key type (1)

Answer

Answer	Description
my-d™ secure Data	Number of keys (1 byte) [Key information (8 bytes)] Free User part (1 byte) Project ID (3 bytes) Logical Sector ID (1 byte) Key type (1 byte) KVV (2 bytes)
DES Data	Number of keys (1 byte) [Key information (10 bytes)] Option byte (1 byte) Free User part (9 bytes)
MIFARE Data	Number of keys (1 byte) [Key information 10 bytes] Free User part (10 bytes)

More than 255 bytes

If the amount of data exceeds 255 bytes, than the answer is divided into more frames.

If a frame follows, the Number of keys byte is extended with a set MSB (80h).

2.3.3.4 Reset key table

The reset key table clears all key entries in the reader. Afterwards the default keys are loaded automatically.

It is only allowed to reset the key table after a successful authentication to the reader.

If no keys are available to login into the reader, it is possible to reset the key table without an authentication.

Command

Command	Data
'rt'	None

Answer

Answer	Description
'RT'	In case of success

2.3.3.5 Update key access rights

This command is able to change the access rights of a key.

It is only allowed to change the access rights after a successful authentication to the reader with a key permitted to change the access rights.

Command

Command	Data
'ua'	Key type (1 byte) Key index (1 byte) Access rights (2 bytes)

Answer

Answer	Description
Data	Access rights (2 bytes). Higher Byte has to be sent first.

Access rights

For more detailed information refer to Get Key Access Rights, page 68.



2.3.3.6 Change key type

This command is able to change the key type. Ensure the key information data are suitable to the key type.

It is only allowed to change the key type after a successful authentication to the reader with a key permitted to change the key type.

Command

Command	Data
'uc'	Key type (1 byte) Key index (1 byte) New key type (1 bytes)

Answer

Answer	Description
Data	Access rights (2 bytes)

2.3.3.7 Update key

The update key command stores, modifies or deletes a key in the reader key table. A key is identified with its key information data. The key information data has to be unique within the same key type.

If a key is erased the key data must be dropped.

It is only allowed to update the key type after a successful authentication to the reader with a key permitted the necessary rights.

Command

Command	Data
my-d™ secure 'uk'	Key type 01h (1 byte) Action (1 byte) Key information data (8 bytes) Free User Part (1 byte) Project ID (3 bytes) Logical Sector ID (1 byte) Key type (1 byte) KVV (2 bytes) Key Data (8 / 16 bytes)
DES 'uk'	Key type 02h (1 byte) Action (1 byte) Key information data (10 bytes) Option (1 byte) Free user part (9 bytes) Key Data (16 bytes)

Command	Data
MIFARE® 'uk'	Key type 03h (1 byte) Action (1 byte) Key information data (10 bytes) Free user part (10 bytes) Key Data (16 bytes)

Answer

Answer	Description
Data	Index of key (1 byte)

Action

The Action byte defines the action of the key.

Action	Description
Axh	Add / Update key
5xh	Delete Key
x1h	my-d™ secure key A
x2h	my-d™ secure key B

my-d™ secure key

For more detailed information on key information data refer to Infineon documentation.

DES key option byte

Bit	Description
0	0 ... 16 byte key 1 ... 8 byte key
1 – 7	RFU

In case of an 8-byte key, the first 8 bytes of the key data are valid.

MIFARE key

Only the first 6 bytes of key data are valid.

Number of stored keys

The key management is able to store up to 32 keys.

Encryption

Key Data for DESFire and MIFARE keys has to be encrypted with the login key in CBC mode. my-d™ S keys are enciphered every 8 byte block separately without CBC mode.

CBC mode

The data stream has to be divided into blocks of 8 bytes. The last enciphered block has to be XORed with the next plain block.

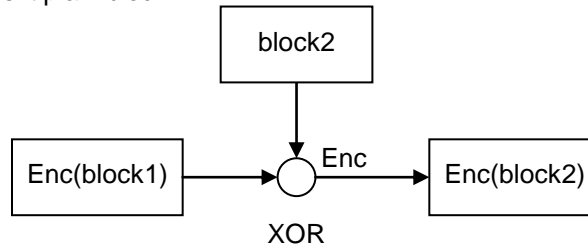

2.3.4 my-d™ secure

Note that ISO 14443 tags do not support the addressed mode. Bit 5 and 6 of the option byte are not used with ISO 14443 tags. The ISO 14443 tag only works in selected mode.

2.3.4.1 Abort KTT upload

This command aborts the Prepare for KTT ‘ut’ command, if the reader is in prepare for KTT awareness mode.

Command

Command	Data
‘*’	None

Answer

Answer	Description
00h	Prepare for KTT successfully aborted
‘F’	Prepare for KTT was not active
No response	Key uploading is in progress

2.3.4.2 Authenticate to sector

The Authenticate to sector command sets up a secured transmission to a transponder.

Command

Command	Data
‘as’	Option byte (1 byte) [UID (8 bytes)] Key page (1 byte) Key index (1 byte) Counter page (2 byte) Diversification data (8 bytes)

Answer

Answer	Description
‘L’	In case of success

**Option byte**

The option byte defines the general behavior of the command.

Note: ISO 14443 tags are only working in selected mode.

Bit	Description
7	RFU
6	If set the tag is in addressed mode. The UID is following as first 8 bytes after the option byte. The my-d™ frame is following.
5	If set the tag is selected. No UID is needed.
4 – 0	RFU

Key page

This byte defines the key page number of the transponder

Key index

Defines the reader key index. If the index exceeds the key index of the reader the error 'R' out of range is thrown. The key index is zero based.

Counter page

This page number points to the authentication counter page. Lower byte of the page number is sent first.

Diversification data

This data is used to diversify the key data.

Example

Command	Answer / Description
'as2004010300000000000000000000'	'L' Login into tag.



2.3.4.3 Issue transponder key

Writes a diversified key to the transponder.

This command uses the write and Reread my-d™ command.

Command

Command	Data
'ik'	Option byte (1 byte) [UID (8 bytes)] Key index (1 byte) Destination page (2 bytes) Diversification data (8 bytes) [Sector index and access conditions (2 bytes)]

Answer

Answer	Description
'IK'	Key successfully written

Option byte

The option byte defines general behavior of the command.

Note: ISO 14443 tags are only working in selected mode.

Bit	Description
7	If set the user mode is used and the MAC is calculated and added to the frame. If not set the issuer mode is used sector index and access conditions are included and no MAC is calculated.
6	If set the tag is in addressed mode. The UID is following as first 8 bytes after the option byte. The my-d™ frame is following.
5	If set the tag is selected. No UID is needed.
4 - 0	RFU

Key index

Defines the reader key index. If the index exceeds the key index of the reader the error 'R' out of range is thrown. The key index is zero based.

Destination page

Defines the transponder page index. Lower byte of the page number is sent first.

Sector index and access conditions

In issuer mode the sector index and the access conditions are added.

2.3.4.4 Prepare for KTT

This command sets the reader into KTT awareness mode.

Command

Command	Data
'ut'	Key page (1 byte) Key index (1 byte) Counter page (2 bytes) Diversification data (8 bytes)

Answer

Use the check KTT upload status '!' command to finish the upload procedure.

LED activity

The green and red LED indicates the state of the upload process.

Mode	LED activity
Awareness	Red and green LEDs are flashing slow
Upload in progress	Green LED is active
Error during upload detected	Red LED is flashing fast until the '!' command is received
Upload finished successfully	Green LED is flashing fast until the '!' command is received
Upload aborted	Red LED is active for 1 second

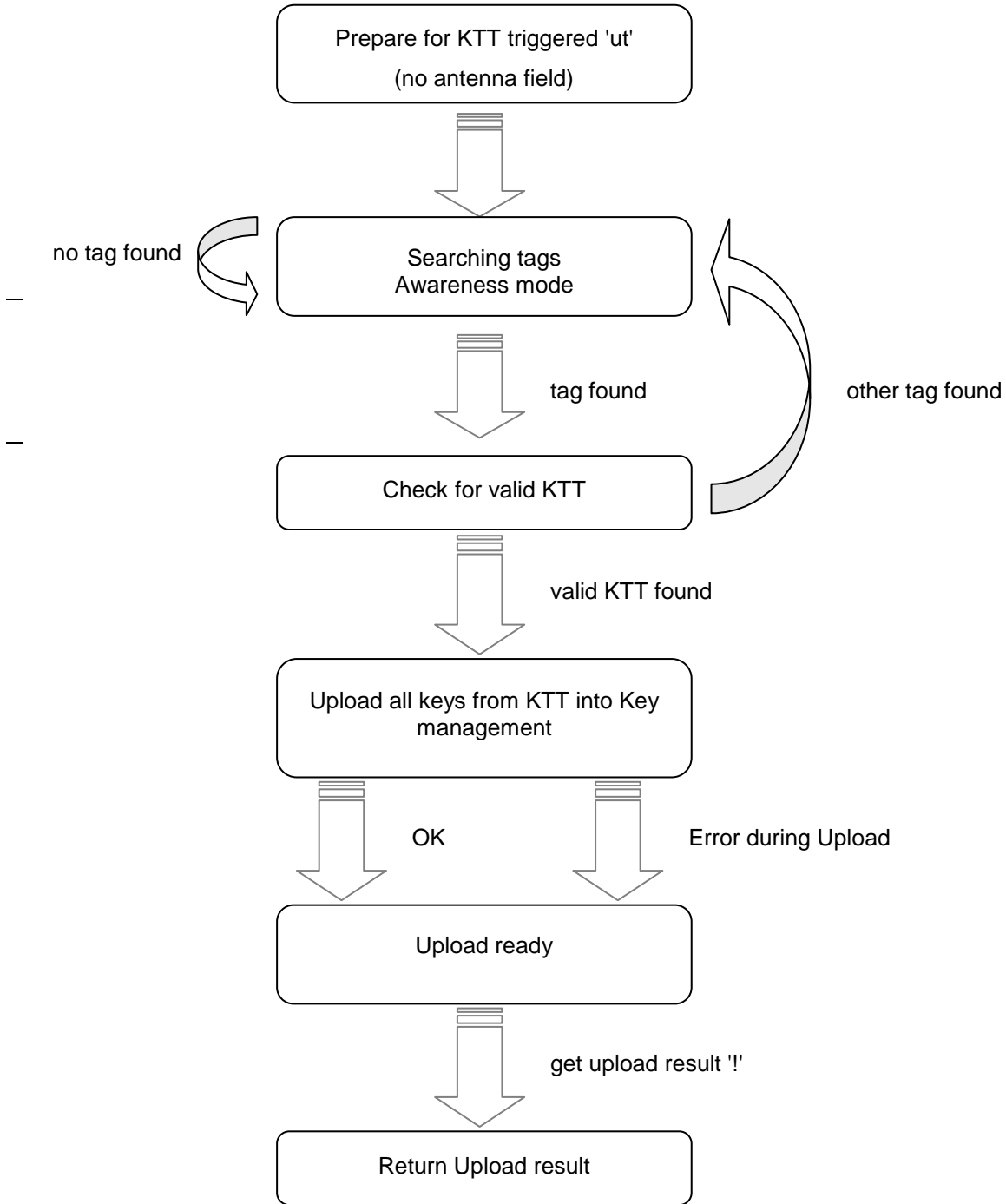

Figure 9 – KTT State Diagram

2.3.4.5 my-d™ command

This command sends and receives my-d™ plain and secure commands including my-d™ secure algorithm.

Command

Command	Data
'z'	Downlink length (1 byte) Option byte (1 byte) [UID (8 bytes)] my-d™ data (n bytes)

Answer

Answer	Description
Data	Status byte: 00h (1 byte) Data without MAC and CRC (n bytes)

Downlink length

This byte is mandatory. It will define the length of the my-d™ data frame sent to the reader. The MAC, CRC and the framing overhead is not included.

Option byte

The option byte defines general behavior of the command.

Note that ISO 14443 tags are only working in selected mode.

Bit	Description
7	If set the MAC is calculated and added to the frame
6	If set the tag is in addressed mode. The UID is following as first 8 bytes after the option byte. The my-d™ frame is following.
5	If set the tag is selected. No UID is needed.
4 – 0	RFU

Data

Data is sent as my-d™ plain command. It contains only data that is processed by the MAC calculation. If the tag is addressed, only valid with ISO 15693 tags, with its UID the first 8 bytes are interpreted as UID and not included into the MAC calculation.

MAC calculation is done automatically if according flag is set. The ISO 15693 or the ISO 14443 frame is completed and the CRC is computed and added automatically.

The commands Write Page, Restricted Write and Write Byte do not need any MAC verification for the answer.



2.3.5 't' Command – Data Frame Transfer

This command allows card-specific communication. The tag type has to be specified first – see Set tag type, page 47 – before issuing a high-speed select command. If successful, the frame waiting time (FWT) is calculated as defined in ISO14443-4, and used instead of the TMR timer if the Extended Protocol flag is set – see Extended Protocol (default 1), page 25. If no FWT is found, TMR is used by default.

Other considerations when using the 't' command

Extended Protocol Flag – bit 6, Protocol configuration 1 register

This flag switches ISO14443-4 handling, including error handling, on or off.

ISO14443-4 Error handling – bit 7, Protocol configuration 2 register

This flag switches ISO14443-4 error handling on or off. Error handling always uses the TMR time-out. The Extended Protocol Flag (above) has to be selected for Error Handling to work.

Receiving more than 256 bytes

The PCB byte of ISO 14443-4 frames contains a chaining bit. This bit is set or has to be set if the number of data does not fit in a single block. Refer to ISO 14443-4 for more detailed information about the chaining mechanism.

Huge Data Mode

In huge data mode the option and length byte of the transfer data command will be turned off to enable larger data transmission. Used is a default value of 0Fh for the option byte.

The full 512 byte data buffer is used in this mode, enabling chaining up to 512 data bytes. In this mode, the answer comprises two length bytes (16bit) followed by the card response.

If using ASCII mode, a trailing <CR> byte is mandatory.

't' command

Command	Data
't'	<p>Normal mode Downlink length (1 byte) <> 0 Option byte (1 byte) Data (n bytes)</p> <p>or</p> <p>Transmit/Receive mode Downlink length (1 byte) = 0 Downlink length new (1 byte) Option byte (1 byte) Transmit byte (1 byte) Receive byte (1 byte) CRC Preset LSB (1 byte) CRC Preset MSB (1 byte) Data (n bytes)</p>

Answer

Answer	Description
Uplink length+Data	Response of card
'C'	Error: Collision
'F'	Error: General failure
'N'	Error: No tag in field [addressed tag not present or not responding]
'O'	Error: Overflow

2.3.5.1 Normal Mode

Downlink length

The downlink length byte contains only the data length. This byte may not be zero. The CRC is computed automatically and is not included in the downlink length.

CRC generation – see [Option Byte - ISO 14443](#) and [ISO 15693](#).

CRC generation is described in ISO 14443-3 Appendix B. If enabled, interpret the CRC with the LSB first. If CRC checking and generation is disabled, the maximum size of data to receive and transmit decreases to 253 bytes.

Option Byte - ISO 14443

This byte contains the transfer options for ISO 14443 and I-Code. For ISO 14443 type B, I-Code and SR176 tags, only bits 2 and 3 are interpreted. The crypto unit is only activated after a successful login.

Bit	Description
0	If set, parity generation is enabled
1	If set, parity is even, otherwise parity is odd
2	If set, CRC generation for transmission is enabled
3	If set, CRC checking for receiving is enabled
4	If set, the crypto unit is deactivated prior to start of transmission. Only the login sequence switches on the crypto unit correctly.
5, 6, 7	Bit framing. Number of bits of the last byte to transmit.

Option Byte - ISO 15693

This byte contains the transfer options for ISO 15693.

Bit	Description
7	If set the CRC is deactivated for transmit.
6	If set the CRC is deactivated for receive.
5 - 0	RFU



Receiving the answer

The reader switches to receiving mode automatically after data is sent. If no data is detected the reader returns the error 'N' no tag in field. If the time-out value (registers 10h and 11h) is too short, the reader will abort the tag detection process before the answer is received. Increase the time-out value and the communication will work.

Answer = 'C' - Collision

If a collision is detected, (more than one tag in the field) the anti-collision sequence is required before accessing the tags. Anti-collision is a complex procedure. The use of Multitag List and Multitag select is recommended – see Multi-Tag Selection / List , page 44.

Answer = Uplink length + Data

This would be the expected response

Examples for ISO14443-A tags (in ASCII mode)

Select sequence for a single tag in the field – refer to ISO14443-3 specification for details

Command	Answer	Description
t 01 E3 26	02 0400	7 bit (E) REQA (code = 0x26) Answer = ATQA (04 00)
t 02 03 93 20	07 0481635640F480	Get full serial number (code=0x93, NVB=0x20). Answer = serial No
t 09 0F 93 70 0481635640F480	01 88	Select card with UID 0481635640F480 Answer = SAK
t 02 0F 30 04	10 010203...	Read block 4: (after login) command code is 0x 30

2.3.5.2 Transmit / Receive mode

Command	Data
't'	Transmit/Receive mode Downlink length (1 byte) = 0 Downlink length new (1 byte) Option byte (1 byte) Transmit byte (1 byte) Receive byte (1 byte) CRC Preset LSB (1 byte) CRC Preset MSB (1 byte) Data (n bytes)

In Transmit / Receive mode, data is sent to the tag in two steps. Furthermore, data is sent and received separately with different options.

This mode only supports ISO 14443 up to part 1-3. (For example Mifare Ultralite tags)

2.3.5.2.1 Downlink length

The downlink length must be zero to activate the Transmit / Receive Mode.

2.3.5.2.2 Downlink length new

The downlink length includes only the data length.

2.3.5.2.3 Option Byte

This byte contains common transfer options.

Bit	Description
0, 1, 3	Bit framing. Number of bits of the last byte to transmit.
4 – 7	RFU

2.3.5.2.4 Transmit Byte

This byte contains transmit transfer options.

Bit	Description
0	If set, the transmission of data is activated.
1	If set, parity generation is enabled
2	If set, parity is odd, otherwise parity is even
3	If set, CRC generation for transmission is enabled
4	If set, an 8-bit CRC is calculated, otherwise a 16-bit CRC is calculated.
5	If set, CRC is calculated according to ISO 14443 B, otherwise it is calculated according to ISO 14443 A.
6, 7	RFU

2.3.5.2.5 Receive Byte

This byte contains receive transfer options.

Bit	Description
0	If set, the receiving of data is activated.
1	If set, parity generation is enabled
2	If set, parity is odd, otherwise parity is even
3	If set, CRC generation for receiving is enabled
4	If set, an 8-bit CRC is calculated, otherwise a 16-bit CRC is calculated.
5	If set, CRC is calculated according to ISO 14443 B, otherwise it is calculated according to ISO 14443 A.
6, 7	RFU

2.3.5.2.6 CRC Preset LSB

This byte contains the LSB of the CRC preset.

2.3.5.2.7 CRC Preset MSB

This byte contains the MSB of the CRC preset.



2.3.5.2.8 CRC generation

CRC generation is described in ISO 14443-3 Appendix B.

The CRC must be interpreted with LSB first.

Examples for ISO 14443 A, Innovision's Jewel tag (in Binary mode)

Sending the 'RID' command

Command	Answer	Description
oa	OA	Set tag type
t00 01 07 01 07 00 00 26	02 00 0C	Send ReqA (26) and receive the answer
t00 01 07 01 00 00 00 78	00	Send first byte of RID command (78)
t00 01 00 01 00 00 00 00	00	
t00 01 00 01 00 00 00 00	00	
t00 01 00 01 00 00 00 00	00	
t00 01 00 01 00 00 00 00	00	
t00 01 00 01 00 00 00 00	00	
t00 01 00 01 00 00 00 00	00	
t00 01 00 01 00 00 00 00	00	
t00 01 00 01 00 00 00 D0	00	
t00 01 00 01 2F FF FF 43	06 00 00 00 00 00 00	Send last byte of RID command and receive the answer

2.3.6 't' command block format & examples

For detailed coding of the Block format refer to ISO 14443-4:2001(E) section 7.1

The 't' command block format is as specified in ISO 14443 part 4, and consists of some or all of the following elements:

Prologue field		Information field	Epilogue field
PCB	[CID]	[NAD]	[INF]
1 byte	1 byte	1 byte	variable
			[EDC]
			2 bytes

PCB – Protocol Control Byte [mandatory]

The PCB is used to distinguish between three different block types (Information, Receive ready and Supervisory) as well as defining if CID is present and conveying block-related flags.

CID – Card Identifier Byte [optional]

4-bit logical card address in the range of 00h to 0Eh, 0F is RFU.

NAD – Node Address Byte [optional]

Should be compliant to NAD as defined in ISO 7816-3.

INF – Information Field [optional]

Commands and data mainly used in the application.

EDC – Error Detection Code [mandatory]

EDC is defined as a 16-bit CRC. The reader calculates the CRC automatically (reference [Option Byte ISO14443](#) and [Option Byte ISO15693](#)).

2.3.6.1 Block formats - Example

Description		Data stream
I-Block (no CID, no NAD)	Application level command	02 INF EDC
I-Block (CID=05, no NAD)	Application level command	0A 05 INF EDC
R-Block (no CID, no NAD)	Acknowledged	A2 EDC
R-Block (CID=06, no NAD)	Not acknowledged	BA 06 EDC

2.3.6.2 ISO-A tag manual activation sequence - Example

For single tag applications

Command	Answer
t01 E3 26	02 04 00 (send REQA)
t02 03 93 20	05 81635640F4 (81635640F4 denotes SN of tag)

For multi-tag applications

Command	Answer
m<CR>	List of accessible tags.

To select a specific tag (after sending REQA)

Command	Answer
t07 0F 93 70 81635640F4	01 88 (Select card 81635640F4)

After selecting a tag, additional parameter selection is done by the RATS sequence.

Command	Answer
t02 0F E0 20 (send RATS)	ATS bytes (refer to ISO 14443-4 section 5.2)

2.3.6.3 ISO-B tag manual activation sequence - Example

For single tag applications

Command	Answer
t03 0C 05 00 08 (REQB, 1 time slot)	0C 50 34030F07 63223344000002

For multi-tag applications: As above, use Multi-Tag List.

To select a specific tag (after sending REQB)

Command	Answer
t09 0C 1D 34030F07 00 02 01 00	01 00



2.3.6.4 Using SLE66CLX320P - Example

Since the SLE66CLX320P supports chip functionality, the transfer command must be used. To set up a communication with the tag, the tag must be appropriately initialized. First the card must be selected and then it is initialized sending the ATS. Afterwards the application specific commands can be issued.

The following table describes the initialization of a SLE66CLX320P:

Command	Answer
s	05 23 74 87 15 1B 04 Select card with UID 05237487151B04
t02 0F E0 50	0F 0F 77 11 E4 02 00 64 05 7D 02 03 31 80 90 00 Send ATS.

2.3.6.5 Using ASK GTML - Example

To work with the ASK GTML tag, the NoRxSOF flag has to be set to 1.

The following table lists 2 examples:

Command	Answer
t03 0C 00 0B 7F	APGEN without ATR
t04 0C 00 0B 3F 80	APGEN with ATR

2.3.6.6 Forcing higher baud rates - Example

To force higher baud rates use the following sequence.

Command	Description
oa	Select tag type
s	Select tag
t02 0F E0 80	RATS
t03 0F D0 11 0A	PPS
h38	Force reader to use 256 Bytes frames
h24	Force reader to use 424kBd

2.3.6.7 Using EAS with I-Code - Example

To get the EAS answer from an I-Code tag enable the EAS bits on page 3 and send the following command with deactivated receiving CRC calculation:

Command	Description
oi	Preselect I-Code
t06 04 E0 00 00 00 00 00	EAS command of I-Code with Family Code 00h and Application Identifier 00h.



2.3.6.8 Examples: How to send ISO 7816 commands?

To work with ISO 7816 commands, the tag has to be set to ISO 14443-4 mode using the high speed select command. The data of the transfer data command is a combination of ISO 14443-4 block format and ISO 7816 command. First the ISO 14443-4 frame data has to be specified (refer to ISO 14443-4): PCB [CID] [NAD] ... PCB is mandatory and the other data bytes are optional. After the block format data of the ISO 14443-4 the ISO 7816 command has to be specified (refer to ISO 7816-4):

Definition of the ISO 7816 GetChallenge command:

CLA	INS	P1	P2	Lc	Data	Le
00h	84h	00h	00h	Empty	Empty	Maximum length of expected response

The following table lists the example with an expected response length of 8:

Command	Answer
t06 0F 02 00 84 00 00 08	GetChallenge command

2.3.7 'e' command – SAM data frame transfer

This command sends a custom data block to a SAM. Refer to ISO/IEC 7816 for more detail.

Note: The SAM interface hardware does not support error repetition and does not check the parity bit. Inverse convention cards are also not supported. T=0 is not supported for non-ISO standard speeds.

There are two versions of this command. A flag bit in the option byte defines the command version. Version 1 is the earlier one, now deprecated. Version 2 now supports ISO/IEC 7816 timeouts (BWT, CWT, WWT) both manual and automatic, TPDU interface for T=0 and a full frame length with buffer mechanism

'e' command

Command	Data
'e'	<p>Version 1: Downlink length (1 byte) Option byte (1 byte) Time-out (1 byte) Transmission factor byte (1 byte) Data (n bytes)</p> <p>Version 2: Downlink length LSB (1 byte) Option byte (1 byte) Downlink length MSB (1 byte) Time-out (1 byte) Transmission factor byte (1 byte) Return length Data (n bytes)</p>



Answer – Version 1

Answer	Description
Data	SAM response
'P'	End of communication
'C'	Error: CRC error
'F'	Error: General failure or incorrect ATR
'N'	Error: No SAM detected

Answer – Version 2

Answer	Description
Error Code	00h – no error 01h – error 02h – wrong parameter 80h – no error, more data available (set chaining bit)
Length	Data length (2bytes): optional, depends on command code used
Data	SAM response

2.3.7.1 Downlink length – Version 1 & Version 2 (LSB)

The Downlink length indicates **only** the data length. It does not include the other header bytes, such as option and transmission factor. For Version 2 this is the LSB byte of the Downlink length.

2.3.7.2 Option byte

This byte contains the transfer options, which are different for each Version.

Table 11 - Version 1 (Option Byte)

Bit	Description
0	Start communication
1	End communication
2	Cold reset
3	RFU
4	T1 length parsing
5	Warm reset
6	T=0 procedure byte 60h processing
7	0h – Version 1

Start communication

If the start communication flag is set, the command responds with an ATR from the SAM. If errors occur, the SAM is automatically switched off and the BCC of the ATR is not checked.

End communication

Do not remove the SAM until End communication is sent.

Cold reset

If cold reset is set, the command responds with an ATR from the SAM after the cold reset of the SAM is complete. In this case, the BCC of the ATR is not checked.

T1 length parsing

If T1 length parsing is set, the length of a T1 frame is checked so there is no additional timeout needed to get all the characters. This only works for frames with 1 byte LRC, but not with 2 bytes CRC.

Warm reset

If warm reset is set, the command responds with an ATR from the SAM after the warm reset of the SAM is done. In this case, the BCC of the ATR is not checked.

T=0 procedure byte 60h processing

If set, the procedure byte 60h of the T=0 protocol is automatically processed.

Table 12 - Version 2 (Option Byte)

Bit	Description
0 - 3	Command code 0h – Transaction 1h – Activation 2h – Deactivation 3h – Warm reset 6h – Cold reset 9h – T1 S(WTX) multiplier all other values are RFU and should not be used
4,5	Protocol 0h – T=0 transmit 1h – T=1 2h – raw mode 3h – T=0 receive
6	Manual timeouts
7	1h – Version 2

Command code – bits 0-3

0h Transaction

This command starts a transaction with the SAM and returns the received data.

- If received data exceeds the host frame limits (indicated with the set chaining bit in the returned error code byte) retrieve the remaining data with the **Receive from Buffer** command.
- If the internal buffer contains any data before executing the transaction command, the transaction data is concatenated with the buffer data to one data stream. The internal buffer is cleared and the complete data stream is sent to the SAM.
- If the received data exceeds the host frame limits, the remaining data are copied into an internal buffer. To receive this data use the **Receive from Buffer** command.

Timeout and return length depends on used protocol type and option byte.



1h Activation

This command activates the SAM and returns an ATR. If an error occurs, the SAM is automatically deactivated.

Timeout, transmission factor and return length are not used.

2h Deactivation

This command deactivates the SAM. Do not remove the SAM until this command is sent.

Timeout, transmission factor and return length is not used.

3h Warm reset

This command makes a warm reset and returns an ATR. If an error occurs, the SAM is automatically deactivated.

Timeout, transmission factor and return length is not used.

7h Transmit to buffer

This command sends up to 11 bytes into the internal buffer. Use this command if the send data exceeds the host frame limits. In addition, use the Transmit to Buffer command just before the Transaction command. The Transaction command automatically concatenates the buffer data with the transaction command data, sending them together to the SAM.

Timeout, transmission factor and return length are not used.

8h Receive from buffer

This command receives the remaining data from the internal buffer.

Note: The internal buffer is cleared after execution.

Timeout, transmission factor and return length are not used.

Protocol – bits 4, 5

The protocol flags are only used for the transaction command.

0h T=0

This protocol type supports a full TPDU interface.

Timeout is used as WWI value if the manual timeout flag is set, otherwise the timeout is automatically taken from the ATR.

Return length is used.

1h T=1

For T=1 protocol include the frame in the data field.

Timeouts are used as BWI/CWI values if the manual timeout flag is set, otherwise the timeouts automatically are taken from the ATR.

Do not use return length.

**2h RAW**

This protocol type uses a fixed timeout of $WT = 9600etu$ and is only supported in the default speed ($F/D=1$).

Send the PPS command with this protocol type.

Timeout is not used.

Return length is used.

3h RFU

Do not use the RFU value.

Manual timeouts – bit 6

If set, the value of the timeout byte is used for $T=0$ and $T=1$ protocol; otherwise the timeouts are automatically taken from the ATR.

2.3.7.3 Time-out**Version 1**

The time-out byte is used as the communication time-out between two characters. One time slice is approximately 9.6ms. If setting the timeout value to zero, use a maximum timeout of 3.6 seconds. Use the TMR timeout until the first character is received.

Version 2

The timeout byte represents the WWI value for $T=0$ protocol and BWI/CWI values for the $T=1$ protocol. BWI and CWI are encoded in the same way as in ATR. (See ISO/IEC 7816-3)

These values are only used if the manual timeout flag is set – see Table 12 - Version 2 (Option Byte).

2.3.7.4 Transmission Factor – Versions 1 & 2

This byte contains the clock rate conversion and baud rate adjustment according to ISO/IEC 7816-3. The default value on start-up is 11h ($F/D = 1$)

The following pairs of F (clock rate conversion factor) and D (baud rate adjustment factor) are supported.

F	D	Description
128 ($F_i=8$)	8, 16, 32 ($D_i = 4,5,6$)	Non ISO standard transmission factor
372 ($F_i=0,1$)	0, 1, 2, 4, 8, 12 ($D_i = 0,1,2,3,4,8$)	ISO standard transmission factors
512 ($F_i=9$)	32, 64 ($D_i = 6,7$)	ISO standard transmission factors



Clock

A clock of 3.39MHz is used.

Transmission Protocol

The supported transmission protocol types are T=0 and T=1. For these protocol types, the ATR is checked.

This command does not process the block frame of the transmission protocol T=1; all bytes are passed through.

The user has to specify the block frame by itself.

DESfire SAM

The non-ISO standard transmission factors supporting baud rates up to 847500 Baud.

Hardware

The SAM interface does not support error repetition and does not check the parity bit.



2.3.8 'e' command block

Examples – Version 1 & 2

Command	Description
e:00 01 10 11 (Version 1)	Start communication
	Answer: ATR
e:00 81 00 10 11 00 (Version 2)	Start communication (T=0)
e:00 91 00 10 11 00 (Version 2)	Start communication (T=1)
	Answer: 00 len-ATR ATR
e:04 00 10 11 FF 11 86 68 (V1)	PPS
	Answer: FF 11 86 68 (if tag agrees with proposal)
e:04 A0 00 10 11 00 FF 11 86 68 (V2)	PPS
	Answer: 00 04 FF 11 86 68 (if tag agrees with proposal)
e:00 20 10 11	Warm reset
	Answer: ATR
e: 00 83 00 10 11 00	Warm reset (T=0)
e: 00 93 00 10 11 00	Warm reset (T=1)
	Answer: 00 len-ATR ATR
e:05 00 10 11 00 84 00 00 08	GetChallenge for T=0
e:09 00 10 11 00 00 05 00 84 00 00 08 89	GetChallenge for T=1. This now includes the T=1 frame
	Answer: reply (varies)
e:05 00 00 10 11 00 00 84 00 00 08	GetChallenge for T=0
e:09 00 00 10 11 00 00 00 05 00 84 00 00 08 89	GetChallenge for T=1. This now includes the T=1 frame
	Answer: 00 len-reply reply (varies)
e:08 00 10 11 00 5A 00 00 03 (3 bytes Df-AID)	SelectApplication for T=0
e:0C 00 10 11 00 00 08 00 5A 00 00 03 (3 bytes DF-AID) EDC	SelectApplication for T=1 This now includes the T=1 frame
	Answer: (2 bytes) – see DESFire SAM spec
e:08 80 00 10 11 00 00 5A 00 00 03 (3 bytes DF-AID)	SelectApplication for T=0
e:0C 90 00 10 11 00 00 00 08 00 5A 00 00 03 (3 bytes DF-AID) EDC	SelectApplication for T=1 This now includes the T=1 frame
	Answer: 00 02 reply – see DESFire SAM spec
e:00 02 00 00	End communication
	Answer: P
e:00 82 00 10 00 00	End communication (T=0)
e:00 92 00 10 00 00	End communication (T=1)
	Answer: 00h

3 Paypass

Paypass is divided into four states:

- Polling
- Activation
- Transaction
- Deactivation

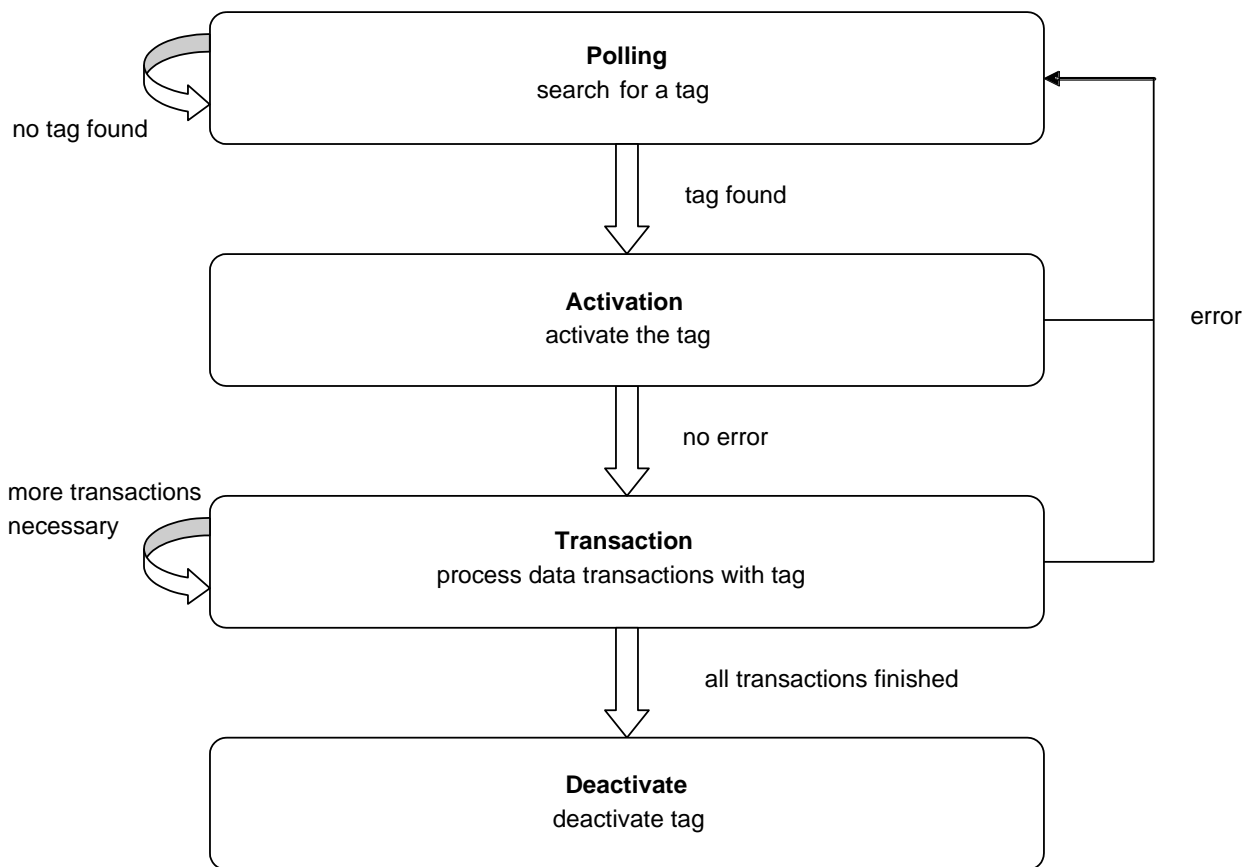

[7]

3.1 Commands

3.1.1 Overview

Command	Description
'pp'	Polling
'pa'	Activation
'pt'	Transaction
'pc'	Transaction: send with chaining
'pm'	Transaction: receive with chaining
'pd'	Deactivation

3.1.2 Return values

All Paypass functions use the same return values:

Return value	Description
00h	No Error
04h	Common error
80h	More data available

3.1.3 Polling

This command scans the field for ISO 14443 A and B cards and returns an error if no tag was found. Loop this command until a tag is found. If a tag was found, the next command is the Activation command.

Command

Command	Data
'pp'	None

Answer

Answer	Description
Error Code	State (1 Byte)

3.1.4 Activation

This command starts the tag activation sequence. If successful the next command is the Transaction command.

Command

Command	Data
'pa'	None

Answer

Answer	Description
Error Code	State (1 Byte)



3.1.5 Transaction

This command starts a transaction sequence with an already activated tag.

Command

Command	Data
'pt'	APDU (n Bytes)

Answer

Answer	Description
Error Code	State (1 Byte)
Length	Data Length (1 Byte)
Data	Data (Length Bytes)

Note: If the error code indicates chaining, the next command is Transaction: Receive with Chaining to get the remaining data from the tag.

3.1.5.1 Transaction - Send with chaining

This command starts a transaction sequence with an already activated tag signaling there is more data available to send to the tag.

Command

Command	Data
'pc'	APDU (n Bytes)

Answer

Answer	Description
Error Code	State (1 Byte)
Length	Data Length (1 Byte)
Data	Data (Length Bytes)

Note: Resend this command until data is available for sending to the tag. Send the last data frame with the transaction command.

3.1.5.2 Transaction - Receive with chaining

This command starts a transaction sequence with an already activated tag.

Command

Command	Data
'pm'	none

Answer

Answer	Description
Error Code	State (1 Byte)
Length	Data Length (1 Byte)
Data	Data (Length Bytes)

Note: Resend this command until no chaining bit is set within the error code.



3.1.5.3 Deactivation

This command starts the tag deactivation sequence. This command returns only if the tag was removed from the field.

Command

Command	Data
'pd'	None

Answer

Answer	Description
Error Code	State (1 Byte)



4 Frequently Asked Questions

4.1 Getting Started

Q. How do I get started?

A To test and interface the MultiISO Compact or Comfort Module, you do not need a sophisticated μ P development system. All you need is a PC, a connection cable and a suitable power supply for the reader. If you are using Microsoft Windows (95/98/NT/XP/...), take the following steps:

- Make sure that your reader has an RS232 interface
- Start HyperTerminal
- Create a new connection (FILE/NEW CONNECTION)
- Enter a name for the connection (i.e. 'MIFARE ')
- Select connect COM2 (COM1) direct connection
- Connection setup 9600,8,n,1,no handshake
- Connect your reader to COM2 (COM1) of the PC and apply appropriate supply voltage. The reader transmits a string ("MultiISO 1.2") to the PC.
- This string denotes the firmware provided with your reader module
- Put a tag to your reader. Serial numbers should be displayed properly

Enter commands (see

- Command Set, page 34) with the keyboard. They should be transmitted to the reader and the reader should reply

If using an operating system different from Microsoft Windows, you may use any other terminal program that is capable of receiving/transmitting data through the serial port of your PC.

4.2 Personalizing Multi ISO Reader

Q. How do I personalize the Multi ISO Reader?

A In ASCII protocol applications, no personalization is necessary.

In applications that are using the binary protocol mode, personalization is required. Use the Utility program to set up your reader correctly. Contact support: eusupport@hidglobal.com to acquire the utility. Minimum requirements are WIN98SE, WIN 2000, WIN XP and a free COM port on the PC.

4.3 MIFARE Card Type

Q. What type of MIFARE card should I use?

A The MIFARE standard is designed for multi-application environments. It contains 16 sectors each with 2 individual keys, access conditions, and 3 data or value blocks. Some applications use the 1 Kbytes of the MIFARE Standard Card Memory only as storage area.

MIFARE Ultra light has no crypto unit on chip. It only supports 16 blocks.

MIFARE Standard 4k cards have the same features as MIFARE Standard cards but increased memory capacity.

4.4 MIFARE

Q. How safe is MIFARE Standard for cashless payment?

A Security is always a feature of the overall system, not of the components. It requires careful design.

A properly designed system will require **ALL** barriers to be hacked in order to be broken.

For good design start identifying possible attacks and then create barriers to block them.

MIFARE was specifically designed for cashless payment applications. The MIFARE concept provides the following security barriers:

- Anti-collision/-selection
- Atomic value transaction
- Ciphared communication
- Storage of values and data protected by mutual authentication
- Weak field keys that allow decrement only
- Stored keys in the reader that are not readable
- Keys in the card that are not readable
- A brute force attack based on trying many different keys is limited by the transaction time (several ms) of the card and would last virtually forever.

The Application can and should provide more barriers:

- Sector access conditions. It is possible to assign access conditions in a way that only decrementing of values is allowed with the keys used in the field. So even a manipulated field station cannot be used to increment the value on the cards. As a general rule, key A is used as a field key, allowing only to read and decrement values, and key B is used to format the card or increment values.
- Diversified keys. To make life even harder for attackers, keys can be modified using the serial number and memory content of the card. So each card uses different keys and a listening attack on the reader interface would be hopeless.
- Limiting cash volume stored on a card



- Do not use the transport keys (keys programmed at the time of delivery) for ticketing applications!
- Ciphared and scrambled data storage
- Sabotage alarm
- Even higher security with contact less controller cards like DESFire, MIFARE ProX, MIFARE Smart MX etc.

Q. How do I use a MIFARE card?

A This example demonstrates the detection of a card in the antenna field with continuous read and the reading of a page.

Command	Answer
C	Activate continuous read mode
	B2197B58 a card responds with its serial number
.	S abort continuous read mode
S	B2197B58 select card
I01AAFFFFFFFFFFFF	L login into sector 1 with key FFFFFFFFFFFFFh key type A
rb04	00112233445566778899AABBCCDDEEFF read block 04
c	Activate continuous read mode to detect a new card

4.5 Using NFC

Q. How do I use NFC?

A The example shows how to communicate with NFC using the NFC demo-board PN531.

The reader is the initiator. The NFC has to be configured as passive target using MIFARE 106kbps (other NFC modes are not supported).

As first step place the reader on top of the NFC demo-board antenna in 3 cm distance.

Then load the "passive_target_106.cmd" file from the "Scripts\Tama\P2P" subfolder into the SCRTester application. Run the code.

Now it is possible to get a serial number from the NFC.

Command	Answer
S	08123456

5 Supported Tags

5.1 MIFARE Transponder Family

The MIFARE transponder family consists of various 13.56 MHz transponder ICs, all compliant to the ISO 14443. Infineon My-D tags that support the MIFARE command set are also included here.

5.1.1 MIFARE Standard

The MIFARE Standard card consists of 16 sectors. A sector includes four blocks of 16 bytes each.

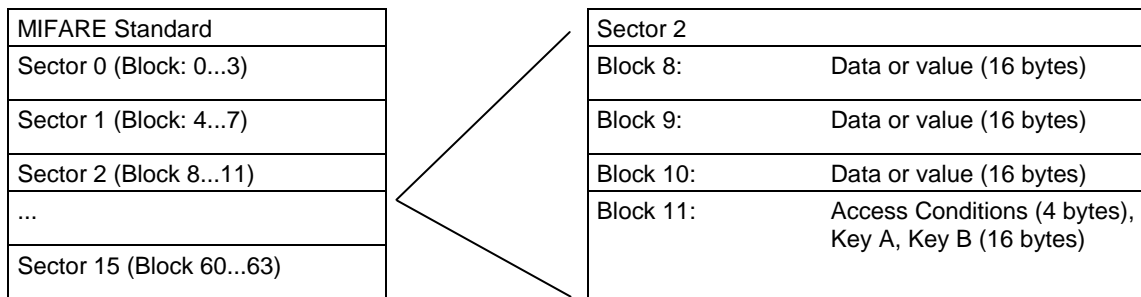

5.1.1.1 Sector 0 / Block 0

Block 0 is read only.

Serial Number (4 bytes)	Check byte (1 byte)	Manufacturer data (11 bytes)
-------------------------	---------------------	------------------------------

5.1.1.2 Blocks 3, 7, 11, 15 ...

Transport keys are set on delivery:

Key A (6 bytes)	Access Conditions (4 bytes)	Key B (6 bytes)
-----------------	-----------------------------	-----------------

Key A

A0 A1 A2 A3 A4 A5 (Infineon) or FF FF FF FF FF FF (new NXP cards)

Key B

B0 B1 B2 B3 B4 B5 (Infineon) or FF FF FF FF FF FF (new NXP cards)

Access Conditions

FF 07 80 xx (key A is used to read or write; key A itself is not readable; key B is data only). For further information refer to the MIFARE card manual.

Remarks

Enabled keys are always read as 00 00 00 00 00 00

Using key B as a data area will cause a security gap, due to the fact that it is necessary to rewrite key A and the access conditions at each write process. It is not recommended to use key B as a data storage area.

All MIFARE cards use the following state diagram.

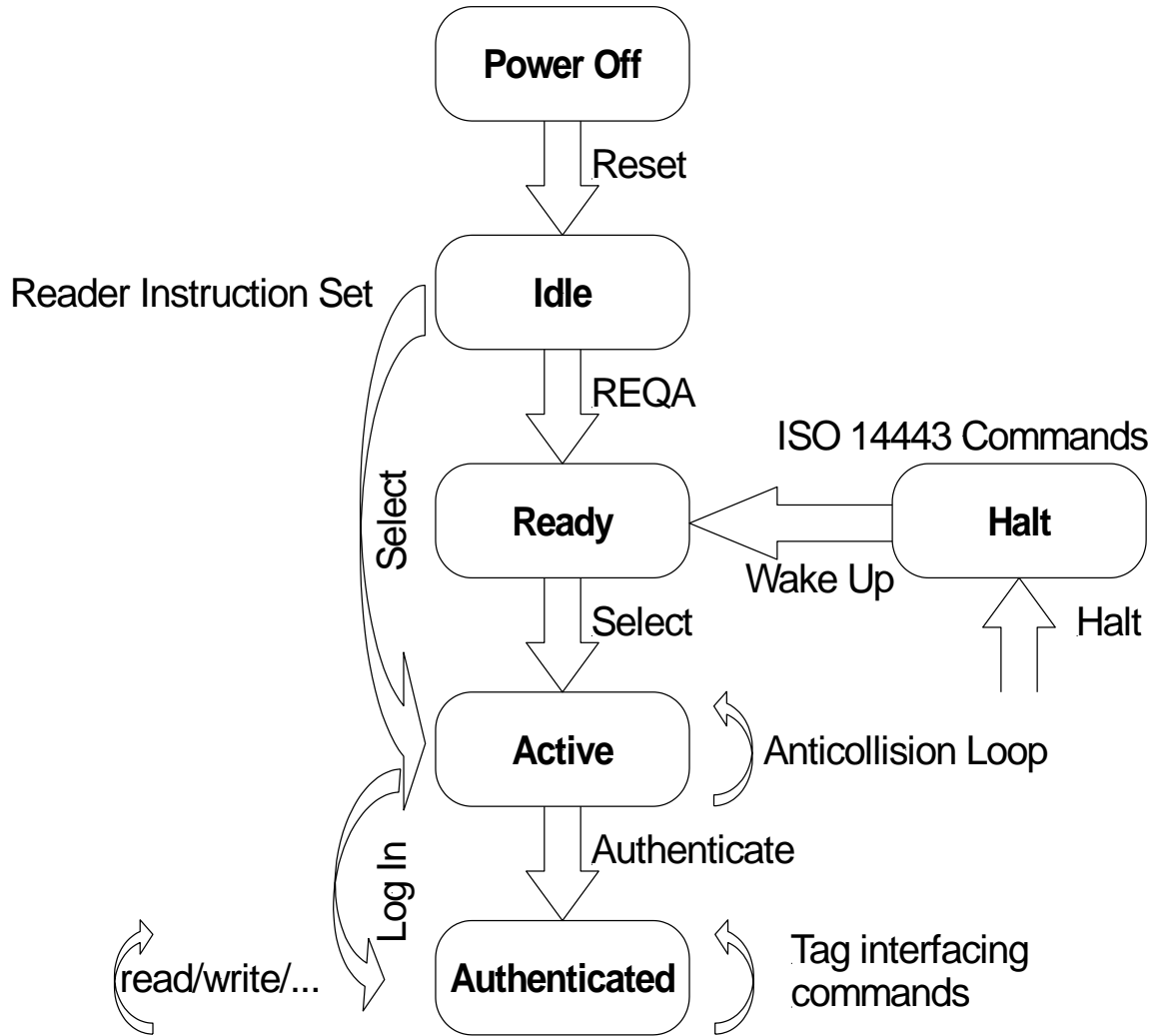

Figure 10 – Mifare State Diagram

5.1.2 MIFARE Ultra-light

MIFARE Ultra-light cards have no encryption included. They only support plain text data transmission.

MIFARE Ultra-light only supports 4 bytes per sector, but the command set uses 16 bytes per sector. Only the 4 least significant bytes are valid when using MIFARE Ultra-light.

Ensure that the other bytes match with the tag content when using the write command; otherwise the read back will fail.

5.1.3 MIFARE 4k

MIFARE 4k cards have an increased memory. Beginning from sector 32 (20h), sectors have 16 blocks. Due to compatibility reasons, the sector indices have changed according to the following table. The login sector has to be used to access the corresponding sector on the card.

Sector	Block	Login sector
00h	00h – 03h	00h
01h	04h – 07h	01h
...
1Fh	7Ch – 7Fh	1Fh
20h	80h – 8Fh	20h
21h	90h – 9Fh	24h
22h	A0h – AFh	28h
23h	B0h – BFh	2Ch
24h	C0h – CFh	30h
25h	D0h – DFh	34h
26h	E0h – EFh	38h
27h	F0h – FFh	3Ch

5.1.4 MIFARE Prox

MIFARE Prox tags have an operating system onboard. Data organization depends on the operating system installed on the card. These cards can include additional functionalities such as DES or a proprietary encipher algorithm.

Before accessing the operating system, the card must be selected. Customized commands are issued using the transfer command.

5.1.5 MIFARE DESFire

This tag supports additional security algorithms (DES, Triple-DES, MAC) for security sensitive applications.

5.1.5.1 Memory organization

The memory of a DESFire card can be personalized to specific requirements. The card can be seen as data storage device like a hard disk in a PC. The memory is divided into a maximum of 28 different applications (directories) with 16 files each. An application has up to 14 keys. Depending on keys and access conditions a file can be accessed in four different ways. Plain data is never secured. Data is secured using a MAC, single DES or triple DES enciphers.

The following figure describes the memory organization of a DESFire card.

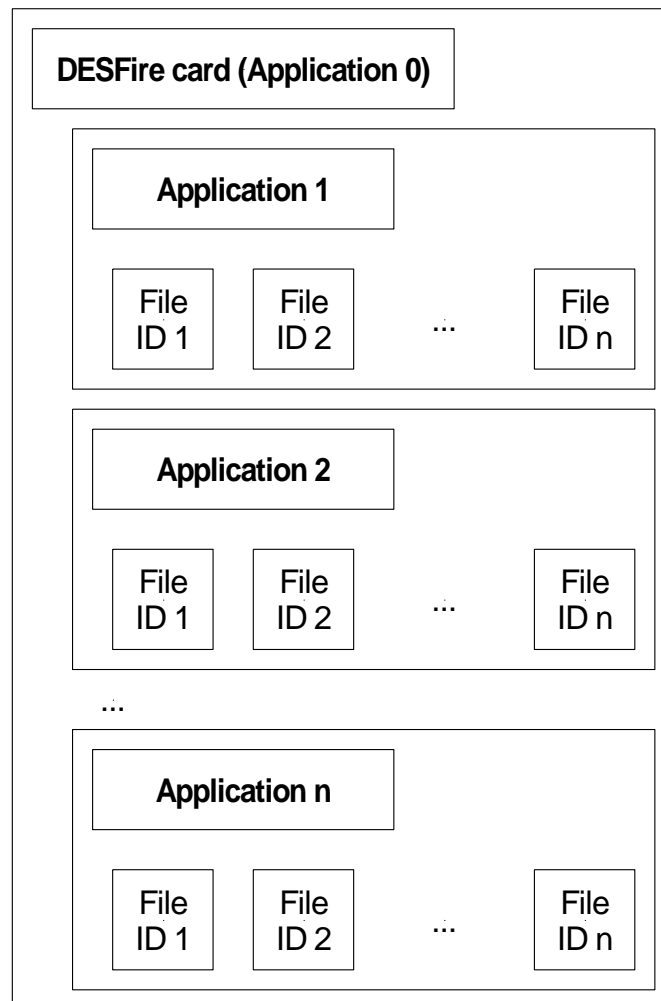

Figure 11 - DESFire Memory

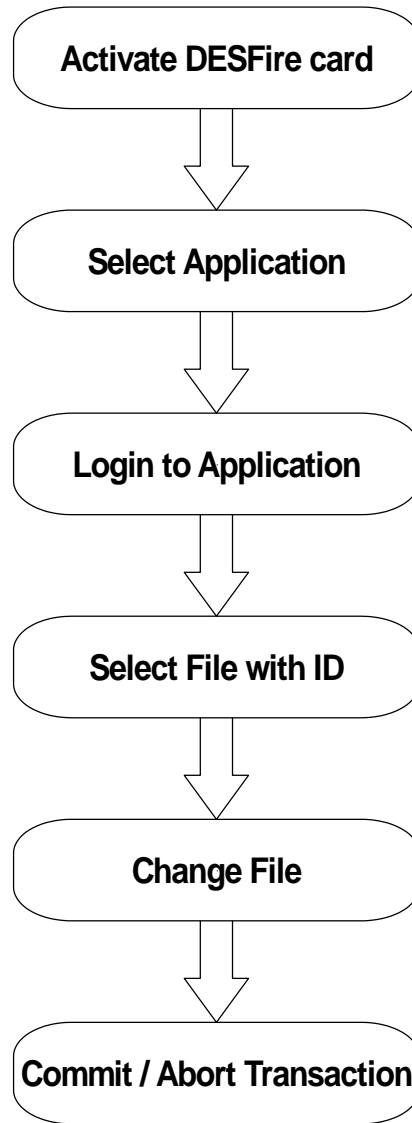

Figure 12 - DESFire State Diagram



5.1.5.2 Activate PICC

Before accessing a DESFire card, the card must be selected. A DESFire card has a 7 byte UID. After activation, the card is powered up and ready to accept a DESFire command. Application 0 is selected automatically.

5.1.5.3 Select application

To jump into another application, the application has to be selected. An application can be seen as a directory, which contains up to 16 files. The size of the application depends on the stored files.

5.1.5.4 Login to application

Specific access rights can be set for each application. Login to an application allows changing the organization of the application. Login to a file opens a secured file for access. A file can be accessed in four different ways: without any security or secured with MAC, single DES or triple DES.

5.1.5.5 Select file

Before accessing a file, the file must be selected

5.1.5.6 Change file

A selected file can be changed according its access rights. If a file is secured, a login is required before changes can be made.

5.1.5.7 Commit / Abort transaction

Value files, backup files, linear record files and cyclic record files only adapt their values after the commit transaction command is given. Several files can be changed within an application at the same time. The abort transactions command annuls all changes within an application. Power loss will cancel all modifications too.

For more details about application settings and access rights refer to [2].

5.1.6 my-d™ IC (SLE 55Rxx)

my-d™ ICs are specific ICs from Infineon. These labels show a different memory organization. Two different modes of tags are supported: plain and secure mode.

Memory Size of SLE Rxx-family

Type	User Memory	Administration Memory	Number of pages
SLE 55R01	128 Bytes	32 Bytes	16
SLE 55R02	256 Bytes	64 Bytes	32
SLE 55R04	616 Bytes	154 Bytes	77
SLE 55R08	1024 Bytes	256 Bytes	128
SLE 55R16	2048 Bytes	512 Bytes	256

Address	Byte number within a page								
	0	1	2	3	4	5	6	7	
FFh	User data								<div style="display: flex; flex-direction: column; align-items: center;"> <div style="margin-bottom: 10px;">SLE 55R01</div> <div style="margin-bottom: 10px;">SLE 55R02</div> <div style="margin-bottom: 10px;">SLE 55R04</div> <div style="margin-bottom: 10px;">SLE 55R08</div> <div style="margin-bottom: 10px;">SLE 55R16</div> </div>
...	...								
7Fh	User data								
...	...								
4Ch	User data								
...	...								
1Fh	User data								
...	...								
0Fh	User data								
...	...								
04h	User data								
03h									
02h									
01h									
00h	Serial number (UID)								



5.2 ISO 14443 Type B

ISO 14443 type B cards are supported.

5.2.1 SR176

The SR176 label contains only 30 bytes of data organized in two bytes per page.

5.2.1.1 Memory organization

Block address	Byte 1	Byte 0	
0Fh	Lock byte	RFU	Chip ID
0Eh	User data		
...	...		
04h	User data		
03h	Serial number		
02h	Serial number		
01h	Serial number		
00h	Serial number		

5.2.1.2 Serial number UID

The UID is stored in the first 4 pages. Page 00h contains the LSB of the UID.

Page 03h		Page 02h		Page 01h		Page 00h	
Byte 1h	Byte 0	Byte 1	Byte 0	Byte 1	Byte 0	Byte 1	Byte 0

5.2.1.3 Lock byte

The lock byte defines the write access condition of a pair of pages. Each bit can only be set once. This procedure is irreversible. This byte is implemented as an OTP.

Bit 7	Bit 6	Bit 5	Bit 4	Bit 3	Bit 2	Bit 1	Bit 0
Page 0Eh Page 0Fh	Page 0Ch Page 0Dh	Page 0Ah Page 0Bh	Page 08h Page 09h	Page 06h Page 07h	Page 04h Page 05h	Page 02h Page 03h	Page 00h Page 01h

5.2.1.4 Chip ID

The Chip ID is defined in the low nibble of page 0Fh. It is manufacturer set and is used internally to select and separate single tags.

5.2.2 SRIX4K

The SRIX4K label contains 512 bytes of data organized into four-byte pages.

5.2.2.1 Memory organization

Block address	Byte 3	Byte 2	Byte 1	Byte 0
FFh	OTP Lock Reg	ST Reserved	ST Reserved	Fixed Chip ID
7Fh	User data			
...	...			
07h	User data			
06h	32 bits binary counter			
05h	32 bits binary counter			
04h	32 bits Boolean Area			
03h	32 bits Boolean Area			
02h	32 bits Boolean Area			
01h	32 bits Boolean Area			
00h	32 bits Boolean Area			

5.2.2.2 Lock block

Locking of blocks is not supported with this tag.



5.3 ISO 15693

The reader can communicate with ISO15693 tags. An anti-collision is needed if multiple instances of tags are in the same antenna field. The reader detects each type of ISO15693 labels and handles them individually

5.3.1 Coding of UID

The UID of a tag is defined in ISO/IEC 15693-3. All tags compliant to ISO15693 support the specified format. The UID is factory programmed and cannot be changed. The UID is needed for the anti-collision sequence to separate several tags in the same antenna field.

Byte							
7	6	5	4	3	2	1	0
E0h	MFR Code	Serial number					

The MFR Code is listed in ISO/IEC 7816-6:1996/Amd.1: 2000(E). Following manufacturers are tested with our reader.

MFR-Code	Company
02h	ST Microelectronics
04h	NXP Semiconductors
05h	Infineon Technologies AG
07h	Texas Instrument
16h	EM Microelectronic-Marin SA

5.3.2 Memory organization

An ISO15693 tag is separated into two blocks. An administrative block contains the UID, AFI, DSFID and the lock page state. The user block is free for custom use. The chip manufacturer defines the amount of bytes and number of pages of each tag. As default four bytes are used for several tags.

Page address	Byte			
	0	1	2	3
3Fh	User data			
...	...			
00h	User data			
Administrative block				

5.3.3 my-d™ IC (SRF55VxxP)

my-d™ ICs are specific ICs from Infineon. These labels show a different memory organization. Two different modes of tags are supported: plain and secure mode.

Two different cards with 320 bytes or 1k bytes EEPROM memory are available. The EEPROM memory is divided into pages.

Each tag is split into two parts: The administrative blocks (00h, 01h, 02h) and the user area. Administrative pages are read only and cannot be changed. User data is free for use. Additionally user data pages can be locked. This procedure is irreversible.

The EEPROM of SRF55V10P is organized in 128 pages addressed 00h to 7Fh. The EEPROM of SRF55V02P consists of 32 pages addressed 00h to 1Fh.

Address	Byte number within a page									
	0	1	2	3	4	5	6	7		
7Fh	User data								SRF55V02P	SRF55V10P
...	...									
1Fh	User data									
...	...									
03h	User data									
02h										
01h										
00h	Serial number (UID)									

5.3.3.1 UID

The UID of SRF55Vxx labels starts with 60h or E0h.

5.3.3.2 Security Bit

Bit 45 of the UID defines the secure mode of the SRF55Vxx. If set, the tag supports security algorithm.

Bit 45	Description
1	Tag supports crypto security mechanism
0	Chip supports plain mode only

5.3.4 EM 4135

The EM4135 is an ISO15693 compliant label of EM Microelectronic-Marin SA. It has eight bytes per page as the same as the my-d™ label. It only supports 36 pages. The administrative area holds the information of the access condition and the UID.

Address	Page							
	0	1	2	3	4	5	6	7
23h	User data							
...	...							
00h	User data							
	Administrative area							

5.4 ICODE

ICODE® IC data is stored in a non-volatile EEPROM. Its capacity is 512 bits organized in 16 blocks consisting 4 bytes each (1 block = 32 bits). First 3 blocks contain administrative data.

5.4.1 Memory organization

Page address	Byte			
	0	1	2	3
0Fh	User data			
...	...			
05h	User data			
04h	Family code identifier / User data			
03h	Special function (EAS) / User data			
02h	Write access condition			
01h	Serial number			
00h	Serial number			

5.4.2 Serial number

The serial number of a label is defined at the manufacturer process. It is stored on page 00h and page 01h. LSB is stored first.

5.4.3 Write access condition

Page 02h contains the write access condition for each page. Each page can be set to read only (bits are set to 0). This procedure is irreversible. Locking page 2 no further changed of the access condition can be done. Always two bits must be change at the same time. This register is implemented as OTP.

Byte 0				Byte 1				Byte 2				Byte 3																		
MSB		LSB		MSB		LSB		MSB		LSB		MSB		LSB																
1	1	1	1	0	0	0	0	1	1	1	1	1	1	1	1	1	1	1	1	1	1	1	1	1	1	1	1	1	1	
3	2	1	0	7	6	5	4	B	A	9	8	F	E	D	C															
Special function	Write access	Serial number	Serial number	User data	:	:	:	:	:	:	:	:	:	:	:	:	:	:	:	:	:	:	:	:	:	:	:	:	:	User data

5.4.4 Special function (EAS,) AFI

Special Functions (EAS) and Family Code/Application Identifier are additional features. For more information refer to the ICODE® manual.

5.4.5 User data

All other blocks are free for use and can be changed if the write access conditions permit.

5.5 ICODE EPC

ICODE EPC labels data is stored in a OTP memory. Its capacity is 136 bits organized in 17 blocks consisting of 1 bytes each. All MSB of the different fields (EPC, CRC16, Destroy Code) are located at the lowest block address.

5.5.1 Memory organization

Page address	Byte
14h – 16h	Destroy Code
12h – 13h	CRC 16
00h – 11h	EPC

5.5.2 Serial number

The serial number of a label is defined within the EPC blocks.

5.5.3 Read Block

It is not possible to read a block with the read block 'rb' command.

5.5.4 Write Block

It is possible to write the EPC data (12 bytes) with the write block 'wb' command using block address 00h.

5.6 ICODE UID

The memory has a capacity of 192 bits and is organized in 24 blocks, consisting of 1 byte each. All MSB of the different fields (UD, UD CRC, CRC16, Destroy Code) are located at the lowest block address.

5.6.1 Memory organization

Page address	Access Condition	Description
21h – 23h	OTP	Destroy Code
19h - 20h	OTP	CRC16
14h – 18h	RO	UID
12h – 13h	R/W	UD CRC16
00h – 11h	R/W	User data (UD)

5.6.2 Read Block

It is possible to read the user data (12 bytes) with the read block 'rb' command using block address 00h.

5.6.3 Write Block

It is possible to write the UD data (12 bytes) with the write block 'wb' command using block address 00h.

Additionally it is possible to write the destroy code (3 bytes) with the write block 'wb' command using block address 01h.



Appendix A - References

- [1] ISO/IEC 14443 Part 1-4, Identification Cards – Contact less integrated circuit(s) cards – Proximity cards
- [2] DESFire Documentation, NXP (formerly Philips), <http://www.nxp.com>
- [3] Data Encryption Standard (DES), FIPS PUB 46-3,
Reaffirmed 1995 October 25
- [4] HID Antenna Design Guide
- [5] NXP (formerly Philips); Application Note, MIFARE & I-Code, Micore Reader IC family Directly Matched Antenna Design
- [6] NXP (formerly Philips) Data sheet MC073933 for CL RC632 Reader IC
- [7] PayPass - ISO 14443 Implementation Specification
PayPass - Terminal

Appendix B - SAM Socket Details

[These details appear in the Hardware Section (1), but are repeated here for convenience]

Note: The power supply to the SAM must be turned off during the entire SAM insertion/withdrawal period; otherwise damage to the SAM may occur

Communication with the SAM is performed using the 'e' command – see 'e' command – SAM data frame transfer, page 86.

When using a SAM with the HID HF MultiISO OEM board, it is recommended that a 100nF decoupling capacitor be fitted between Vcc and GND close to the SAM socket to ensure proper operation. The complete circuit diagram is shown below.

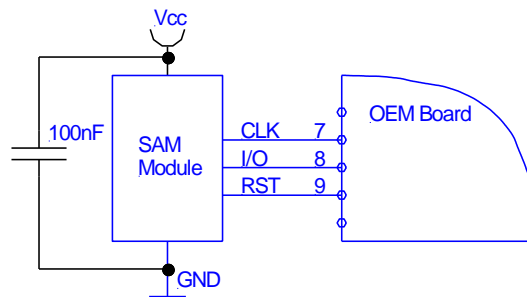

PIN-out for an 8 Pin SAM Socket and for a 6 Pin SAM Socket

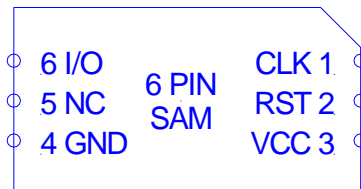
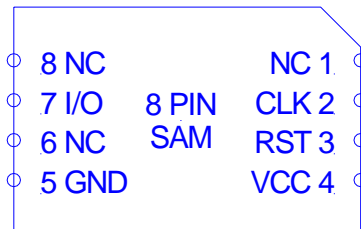



Appendix C - Timings

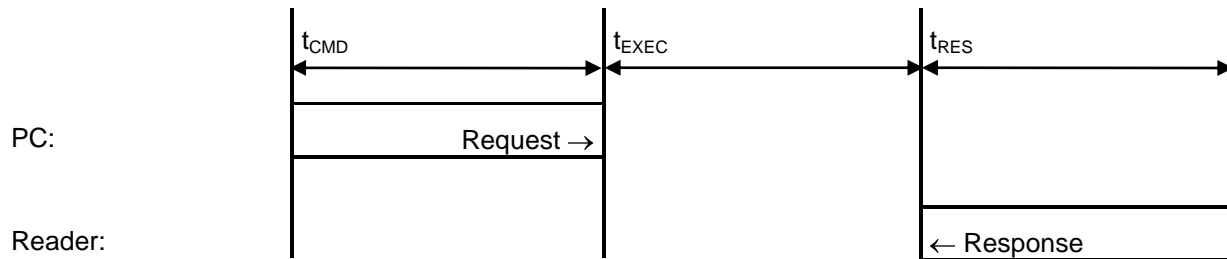

Table 13 - Timings

Command	t_{EXEC} [ms]	Comments
Common commands		
Cont. read (locked tag)	2.8 – 22.6	+ Reset Off and Recovery Time
Cont. read (worst case)	54	+ 3x Reset Off and Recovery Time
DES en/decryption	9.6 – 9.7	
TDES en/decryption	28.7 – 28.8	
High-speed select 'h08' (locked tag)	8.9 – 14.4	+ Reset Off and Recovery Time + SFGT
High-speed select 'h08' (no tag)	15	+ 3x Reset Off and Recovery Time
High-speed select 'h08' (worst case)	14.7	+ 3x Reset Off and Recovery Time + SFGT
Multi-select (locked tag)	5.8 – 11.4	+ Reset Off and Recovery Time
Multi-select (no tag)	67	+ Reset Off and Recovery Time
Multi-select (worst case)	67	+ Reset Off and Recovery Time
Antenna on	0.2	+ Reset Recovery Time
Antenna off	0.2	
Port read	0.1	
Port write	0.1	
Read block	1.8 – 2.2	
Write block	8.2 – 11	
Reset	13.2	
Select (locked tag)	5.4 – 22.8	+ Reset Off and Recovery Time
Select (no tag)	38	+ 3x Reset Off and Recovery Time
Select (worst case)	55	+ 3x Reset Off and Recovery Time



Command	t _{EXEC} [ms]	Comments
ISO 14443 Type A only commands		
Increment value block	18.4	
Decrement value block	18.4	
Copy value block	18.5	
Read value block	2.3	
Write value block	7.9 - 10.5	
MIFARE Login	4.9	
Power conditions		
Power on	79	Does not include rise time of power supply
Enable on	85	

Used was the default Command Guard Time (20h = 1.2ms).

All timing data is advisory application information and does not form part of the specifications. It may change in future firmware releases.

Note: All values specified in Table 13 - Timings depends on the tag used and Command Guard Time.

Appendix D

5553 Reader Board RS232 Compact MultiISO (RDHC-020xN0-02)

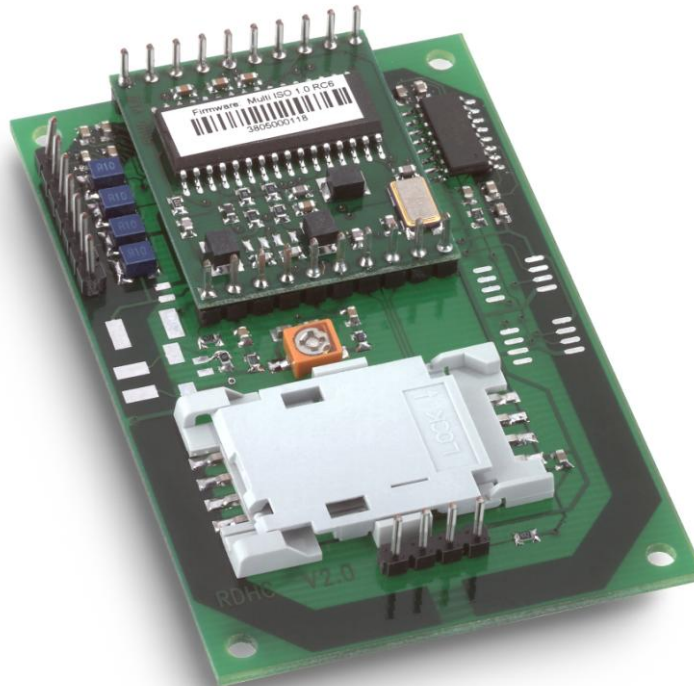

Features

- Interface type: RS232
- Dimensions: 70x45x12.1 (LxWxH), all in mm
- Reading Distance: up to 75mm, depending on the tag
- SAM: supported
- Boot loader: supported ⁽¹⁾
- Drivers: DLL driver available
- Antenna: on board
- Signaling: reading LED, power LED
- Power Supply: 5VDC ± 10% regulated

⁽¹⁾ The boot loader makes it easy to download new firmware to the unit without replacing or dismantling the hardware.

Dimensions

All dimensions are listed in millimeters.

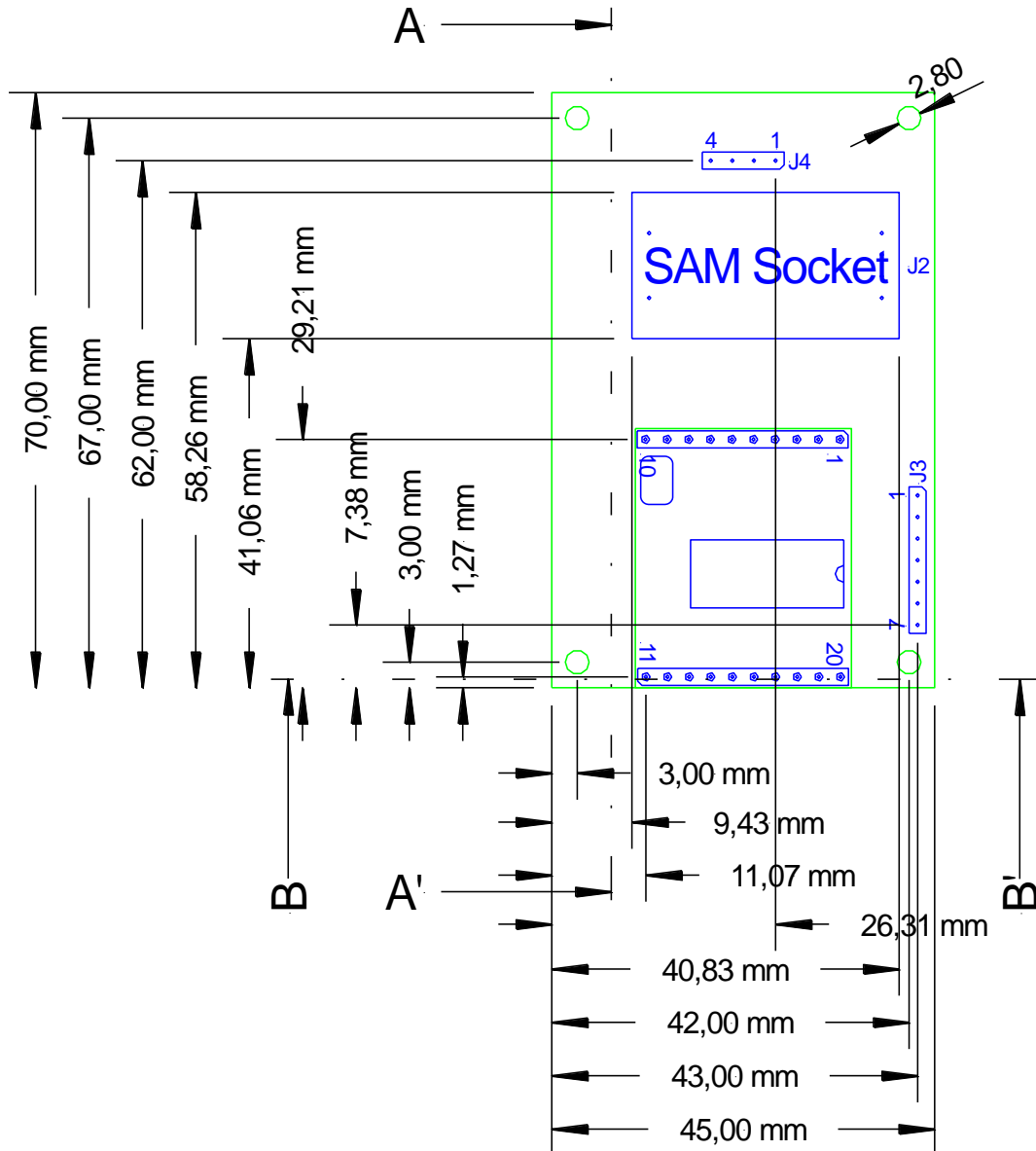

Figure 13 - 5553 Reader RS232 Compact Multi ISO - Top View

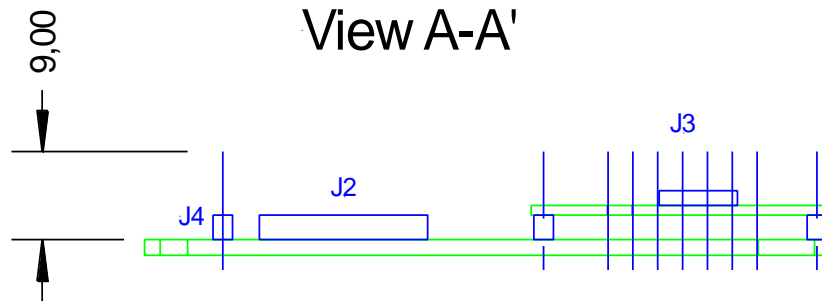

Figure 14 - 5553 Reader RS232 Compact Multi ISO - Side View

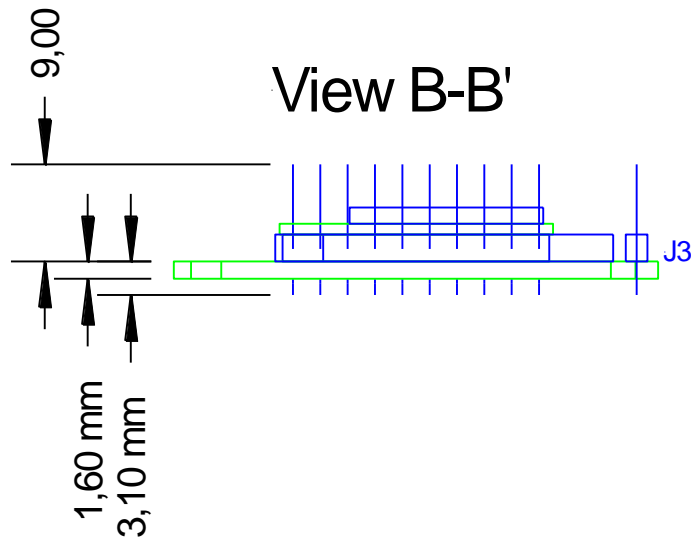

Figure 15 - 5553 Reader RS232 Compact Multi ISO - Front View

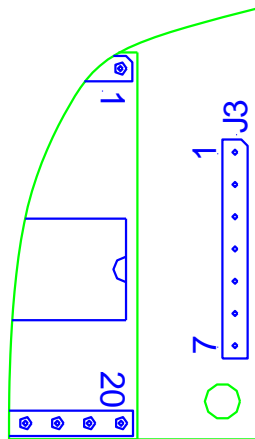

Figure 16 - Pin Out – Jumper 3

Table 14 - Pin out – Jumper 3 Detail

PIN	PIN No.	Description
RFU	1	RFU
+5V	2	Supply Voltage
GND	3	Ground
RX/RXA	4	RS232 RX / RS422 RXA
TX/TXA	5	RS232 TX / RS422 TXA
RXB	6	RS422 RXB
TXB	7	RS422 TXB

Table 15 - J3 pins in RS232 Configuration - Electrical Characteristics

PIN	PIN No.	Min	Typ.	Max.	Description
RFU	1				Do not connect
+5V	2	4.5V	5V	5.5V	Supply Voltage
			150mA	250mA	Supply Current (without SAM)
GND	3		GND		Ground for Power Supply and Interface
RX/RXA	4	-15V 3kΩ	5kΩ	+15V 7kΩ	RS232 Voltage Levels Input Impedance
TX/TXA	5	±5V 300kΩ	±9V		RS232 Voltage Levels Output Impedance
RXB	6				Do not connect
TXB	7				Do not connect

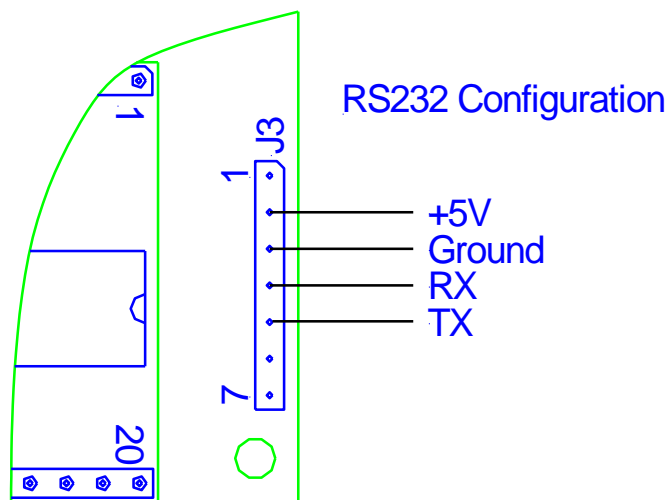

Figure 17 - RS232 Configuration - Jumper 3 Pin Out

Table 16 - J3 pins in RS422 Configuration - Electrical Characteristics

PIN	PIN No.	Min	Typ.	Max.	Description
RFU	1				Do not connect
+5V	2	4.5V	5V	5.5V	Supply Voltage
			150mA	250mA	Supply Current (without SAM)
GND	3		GND		Ground for Power Supply and Interface
RX/RXA	4	-7V		+12V	RXA RS422
TX/TXA	5	-7V		+12V	TXA RS422 / Differential
RXB	6	-7V		+12V	RXB RS422
TXB	7	-7V		+12V	TXB RS422 / Differential

Description	PIN No.	Conditions	Min	Typ.	Max.
Differential Output Voltage	4/6	Unloaded	GND		V _{CC}
Differential Output Voltage	5/7	Loaded: R _L =50Ω	2V		V _{CC}

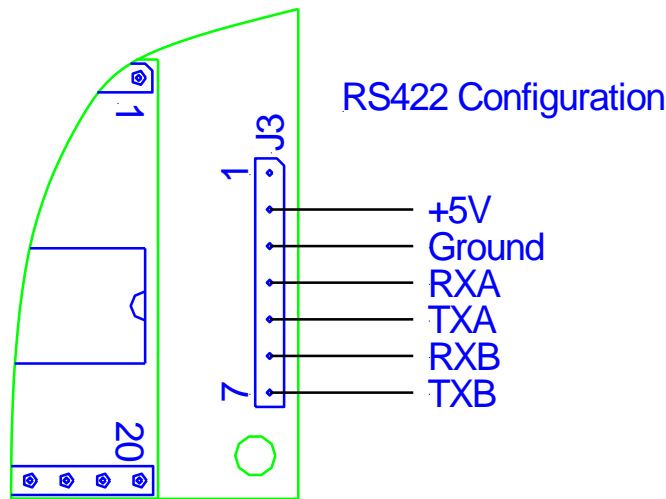

Figure 18 - RS422 Configuration - Jumper 3 Pin Out

Table 17 - J3 pins in RS485 Configuration - Electrical Characteristics

PIN	PIN No.	Min	Typ.	Max.	Description
RFU	1				Do not connect
+5V	2	4.5V	5V	5.5V	Supply Voltage
			150mA	250mA	Supply Current (without SAM)
GND	3		GND		Ground for Power Supply and Interface
RX/RXA	4	-7V		+12V	RX, connect to PIN 5
TX/TXA	5	-7V		+12V	TX
RXB	6	-7V		+12V	RX, connect to PIN 7
TXB	7	-7V		+12V	TX

Description	PIN No.	Conditions	Min	Typ.	Max.
Differential Output Voltage	4/6	Unloaded	GND		V _{CC}
Differential Output Voltage	5/7	Loaded: R _L =270Ω	1.5V		V _{CC}

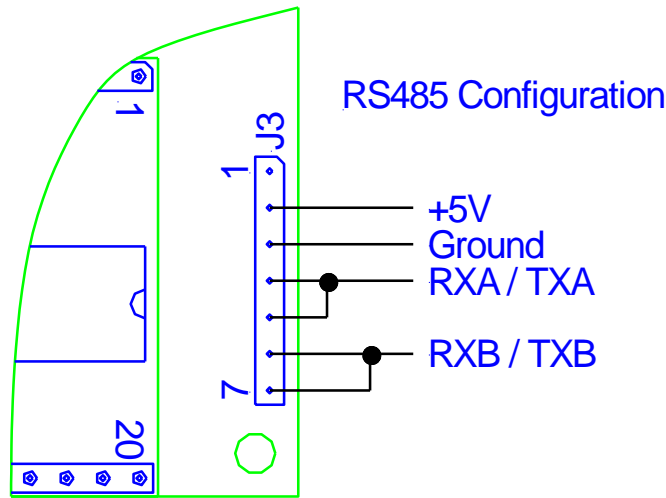

Figure 19 – RS485 Configuration - Jumper 3 Pin Out

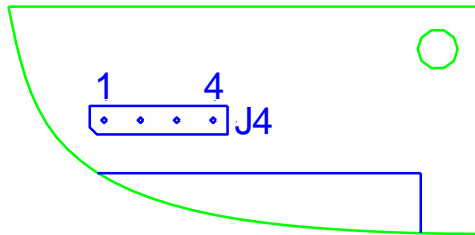

Figure 20 - Jumper 4 Pin Out - Top View

PIN	PIN No.	Description
Read+	1	Connector for green Read Indicator LED
Read-	2	Connector for red Read Error Indicator LED
Power-	3	Ground
Power+	4	Connector for Power Indicator LED

Table 18 - J4 pins - Electrical Characteristics

PIN	PIN No.	Min	Typ.	Max.	Description
Read+	1		1.4V @11mA	VDD _{max}	
			11mA	@15mA	
Read-	2		1.4V @11mA	VDD _{max}	
			11mA	@15mA	
Power-	3		GND		
Power+	4		1.4V @11mA	VDD _{max}	
			11mA	15mA	

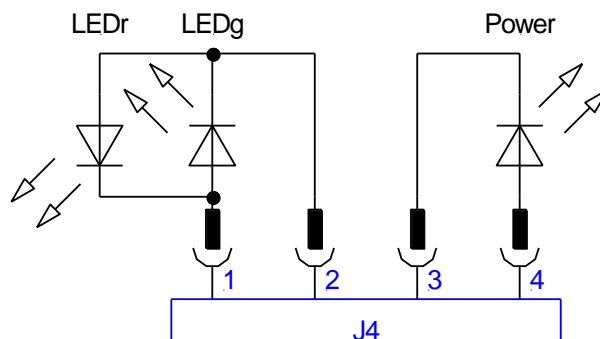
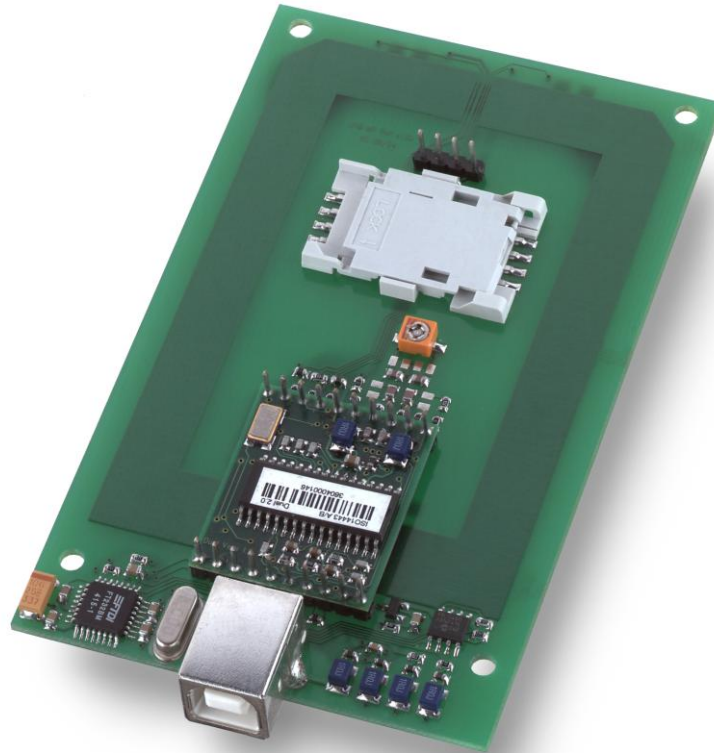

Figure 21 - Jumper 4 Pin Out

5553 Reader Board USB Comfort Multi ISO (RDHS-0204N0-02)



Features

- Interface type: USB 2.0
- Dimensions: 110x70x14 (LxWxH), all in mm
- Reading Distance: up to 90mm, depending on the tag
- SAM: supported
- Boot loader: supported ^(?)
- Drivers: virtual COM port driver, DLL driver, PCSC driver available
- Antenna: on board
- Signaling: reading LED, power LED
- Power Supply: through USB

^(?) The boot loader makes it easy to download new firmware to the unit without replacing or dismantling the hardware.

Dimensions

All dimensions are listed in millimeters.

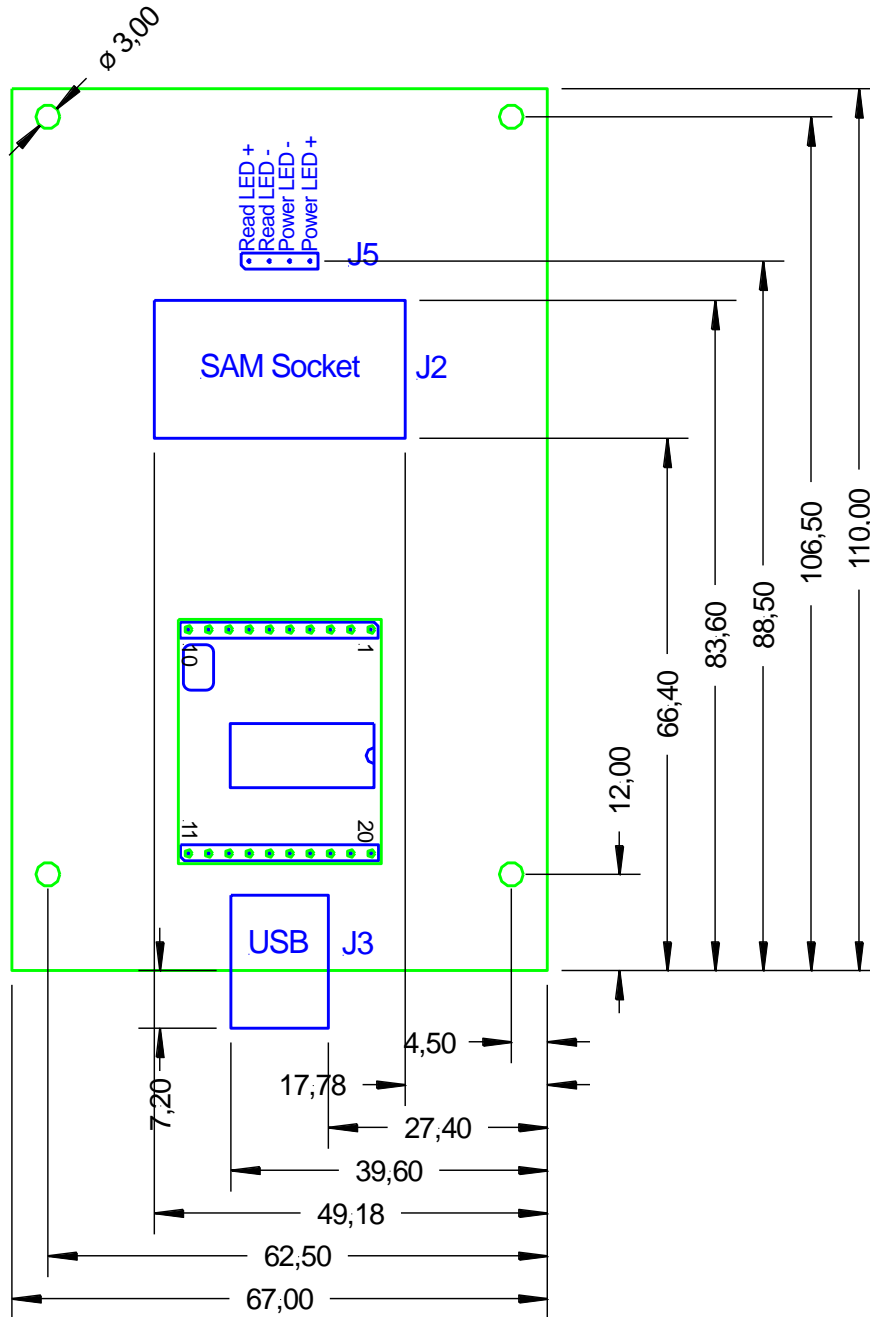

Figure 22 - 5553 Reader USB Comfort Multi ISO - Top View

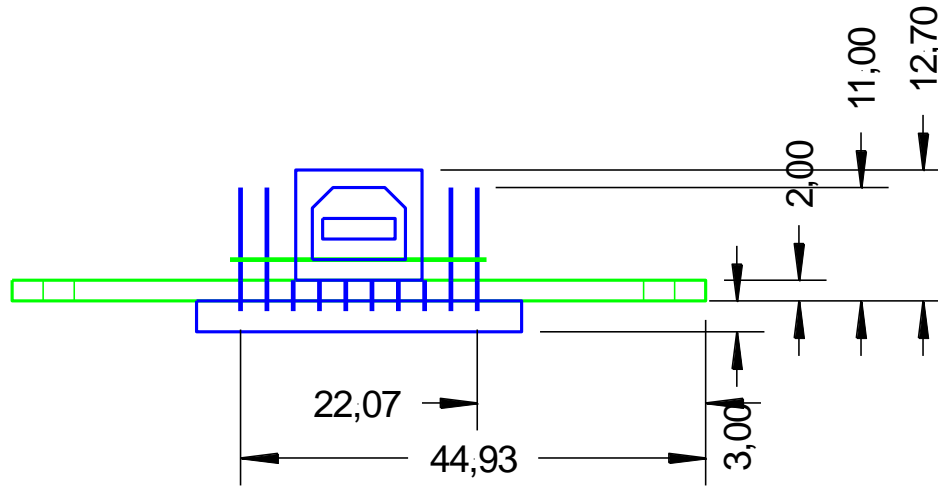

Figure 23 - 5553 Reader USB Comfort Multi ISO - Front View

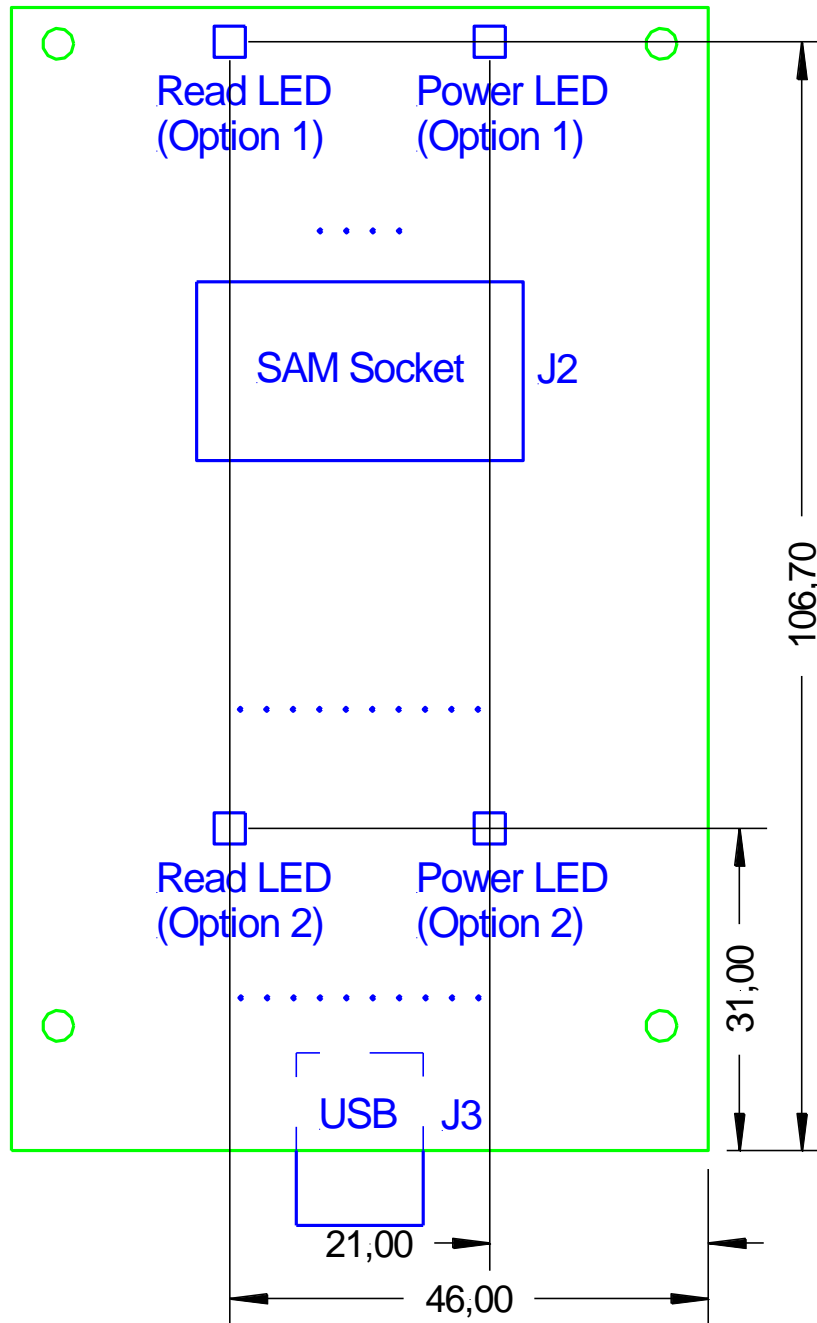

Figure 24 - 5553 Reader USB Comfort Multi ISO - Bottom View

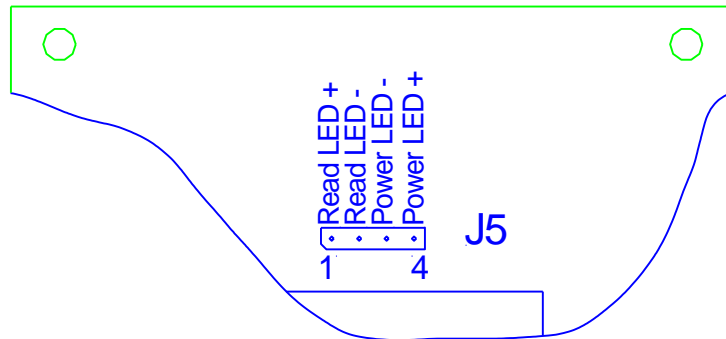

Figure 25 - 5553 Reader USB Comfort Multi ISO - Jumper 5 Pin Out - Top View

Table 19 - Pin Out of Jumper 5

PIN	PIN No.	Description
Read+	1	Connector for green Read Indicator LED
Read-	2	Connector for red Read Error Indicator LED
Power-	3	Ground
Power+	4	Connector for Power Indicator LED

Electrical characteristics of J5 pins

Table 20 – J5 Pin - Electrical Characteristics

PIN	PIN No.	Min	Typ.	Max.	Description
Read+	1		1.4V @11mA	VDD _{max}	
			11mA	@15mA	
Read-	2		1.4V @11mA	VDD _{max}	
			11mA	@15mA	
Power-	3		GND		
Power+	4		1.4V @11mA	VDD _{max}	
			11mA	15mA	

5553 Desktop Multi ISO (RDHS-0204D0-02)



Features

- Interface type: USB 2.0
- Dimensions: 155x82x35 (LxWxH), all in mm
- Reading Distance: up to 80mm, depending on the tag
- SAM: supported
- Boot loader: supported (?)
- Drivers: virtual COM port driver, DLL driver, PCSC driver available
- Antenna: on board
- Signaling: reading LED, power LED
- Power Supply: through USB

(?) The boot loader makes it easy to download new firmware to the unit without replacing or dismantling the hardware.

4553 Mobile Multi ISO (RDHP-0206P0-02)



Features

- Interface type: CF Card Type II
- Dimensions: (LxWxH) 86.50x43.0x10.0mm \pm 0.1mm (LxWxH)
- Reading Distance: up to 60mm, depending on the tag
- SAM: not integrated
- Boot loader: supported (?)
- Drivers: virtual COM port driver, DLL driver available
- Antenna: integrated
- Signaling: reading LED integrated
- Power Supply: through CF Card Interface

(?) The boot loader makes it easy to download new firmware to the unit without replacing or dismantling the hardware.



Appendix E - Version History

07/07/2009	Contents of the Security Manual incorporated Command table hyperlinks added Explanations clarified and examples added Text updated to reflect latest Brand names	Version 1.2, Rev B.0
10/22/2008	Extended ID supports the ISO 14443 A SAK byte High Level support of the Innovision Jewel tag (selection, read and write operations) Added functionality to switch between ReqA/B or WupA/B usage The Quiet command now supports ISO 14443 part 3 and 4. Improved ISO 14443 4 handling Changed LED behavior in continuous read mode and multi-list Increased LED flash duration time New command "ox" added to reread all register settings Basic Paypass 1.0 functionality Improved SAM handling & support for new NXP SAM.	Version 1.2, Rev. A.0
09/06/2006	Register default value changed for Selection Timeout ISO 14443 B Support of asynchronous baud rates for the high-speed select command Improved support of read / write operations for LRI tags Added commands to read and write multiple blocks ('rd' / 'wd') Flag added to disable read after write Bug fixes	Version 1.1, Rev. 1.0
09/02/2005	Initial Release	Version 1.0, Rev. 1.0



Appendix F - Approvals / Certificates

CE Declaration

HID Global declares that, in conformity with the European CE requirements specified in the EMC Directive 89/336/EEC, the HID HF Multi ISO Plug & Play Modules, the HID HF Multi ISO Desktop Reader and the Plug-In Reader Module, described in this manual, are

CE compliant

The relevant documents are available.

If any of the Multi ISO Plug & Play Modules or the CF Card Reader Module is operated from a mains power supply, all power connections and additional components of the final device must also comply with the EMC Directive 89/336/EEC directive.

Customers selling into Europe must themselves make sure that the final device conforms to the EMC Directive 89/336/EEC directive.

The compliance of important international regulations into business practices are a priority and the implementation of the EMC Directive 89/336/EEC is fully in line with the company's commitment to continuously improve its Quality Management System.



FCC Declaration

HID Global declares that, in conformity with the U.S. Directive FCC part 15, HID HF Multi ISO Plug & Play Modules, the HID HF Multi ISO Desktop Reader and the Plug-In Reader Module, described in this manual, are

FCC part15 compliant

The relevant documents are available.

If any of the Multi ISO Plug & Play Modules or the CF Card Reader Module is operated from a mains power supply, all power connections and additional components of the final device must also comply with the US FCC Part 15 directive.

Customers selling into the USA must themselves make sure that the final device conforms to the US FCC Part 15 directive.

Caution: Any changes or modifications not expressly approved by the party responsible for compliance could void the user's authority to operate the equipment.

For HID Identification Technologies GmbH, the compliance of important international regulations into business practices are a priority and the implementation of the FCC part 15 is fully in line with the company's commitment to continuously improve its Quality Management System.

RoHS Compliance

HID Global declares that, in conformity with the Directive 2002/95/EC about the Restriction of Hazardous Substances (RoHS), its HID HF Multi ISO RFID Reader products, listed in this manual, are

RoHS compliant

The following substances are contained in accordance with the limits required by the Directive.

- Cadmium and cadmium compounds
- Lead and lead compounds
- Mercury and mercury compounds
- Hexavalent chromium compounds
- Polybrominated biphenyls (PBB)
- Polybrominated Diphenylethers (BPDE)

For HID Global, the integration of environmental considerations into business practices is a priority and the implementation of RoHS Directive is fully in line with the company's commitment to continuously improve its Quality Management System.